



Description

The DAS series inclinometers are range of high performance low cost dual axis tilt sensors for measurement of angle in both the pitch and roll axes. They utilise a very high performance MEMS sensor which exhibits low long term & temperature drift compared with many competitive devices. Each sensor is packaged in a small, robust, sealed Aluminium housing and is supplied with a 2m screened PUR cable terminated with a 4 pin M12 connector. The high resolution output voltage varies from 0.5-4.5V over the range of the sensor. There are three measurement range options available: $\pm 10^\circ$, $\pm 30^\circ$ & $\pm 90^\circ$, and a further two supply voltage level options: 5V (DC), or 7V to 32V (DC). These sensors are CE certified, and are manufactured and individually tested in our UK factory to guarantee performance to the stated specifications.



Features

- Dual axis, measuring ranges : $\pm 10^\circ$, $\pm 30^\circ$ or $\pm 90^\circ$
- Input supply options: 5Vdc or 7-32Vdc
- Sealed to IP67
- Solid state MEMS sensor
- High resolution 0.5-4.5V voltage output
- Low cost relative to performance
- Small size, 46 x 43.5 x 13.5mm
- 2 meter cable with braided screen & M12 connector

Typical Applications

- Position feedback for solar tracking systems
- Platform levelling and monitoring
- GPS compensation
- Agricultural and industrial vehicle tilt monitoring
- Telescopic and scissor lift platform monitoring
- Platform scales and weigh bridge levelling
- Robotics position sensing
- Can be readily customised to suit most applications

Specifications

Parameter	Value	Unit	Notes
Supply Voltage DAS-XX-A Version	7-32	V dc	Supply is filtered, suppressed and regulated internally, however we recommend the use of a low noise supply to prevent noise coupling to the sensor.
Supply Voltage DAS-XX-R Version	5.00	V dc	A clean and stable input supply should be used, DAS-XX-R models are not regulated internally. For greatest accuracy, the supply voltage level must account for the resistance of the cable.
Operating Current DAS-XX-A Version DAS-XX-R Version	20 18	mA mA	The supply current will vary depending on the Voltage supplied to the sensor, the values shown are maximum.
Operating Temperature	-40 to 85	$^\circ\text{C}$	This is the maximum operating temperature range.
Frequency Response	3	Hz	This is the frequency at which the output is 3dB less than the input value.
Mechanical shock	5000	G	Shock survival limit for internal sensor 5000G for 0.5ms.
0° Output Level	2.5	V	For optimum zero point accuracy, mounting of the part can be adjusted.
Output Impedence	100	Ω	
Output Range	0.5 - 4.5	V	See page 4 for more details.
Cable	2	m	4 core braided screen cable with black PUR jacket (see page 5 for details).
Connector	M12	-	4 pole M12 male connector (see page 5 for details).
Sealing	IP67	-	Applies to housing, cable gland & connector (while attached to female M12). Gland is not designed for flexible cable installation which may compromise the seal.
Weight	90	g	Including cable.
Size			
Width	46.0	mm	
Length	43.5	mm	
Height	13.5	mm	



Performance & Output Specifications

Parameter	DAS-10-A	DAS-10-R	DAS-30-A	DAS-30-R	DAS-90-A	DAS-90-R	Unit
Measuring range	±10	±10	±30	±30	±90	±90	°
Zero Bias Error	±0.01	±0.01	±0.03	±0.03	±0.08	±0.08	°
Accuracy (20°C)	±0.07	±0.10	±0.07	±0.22	±0.15	±0.39	°
Sensitivity For first 1° For 1g range	201 11.518	201 11.518	70 4	70 4	35 2	35 2	mV/° V/g
Temperature Errors Zero Drift Sensitivity Drift	±0.0015 ±0.0030	±0.0015 ±0.0030	±0.0015 ±0.0030	±0.0015 ±0.0030	±0.0015 ±0.0030	±0.0015 ±0.0030	°/°C %/°C
Accuracy (-10 to 60°C)	±0.15	±0.18	±0.20	±0.35	±0.34	±0.58	°
Long Term Stability	±0.01	±0.01	±0.01	±0.01	±0.01	±0.01	°
Resolution (@3Hz bandwidth)	0.001	0.001	0.002	0.002	0.003	0.003	°

Parameter	Notes
Measuring range	Defines the calibrated measurement range.
Zero Bias Error	This is the maximum angle from the device when it is placed on a perfectly level surface. For optimum zero point accuracy, the mounting angle of the part can be adjusted.
Accuracy (20°C)	This is the maximum error between the measured and displayed value at any point in the measurement range (up to ±45°) when the device is at room temperature (20°C).
Sensitivity	This is the nominal amount that the voltage will change with when tilted throughout the range specified. The output is proportional to the Sine of the input, so the sensitivity changes throughout the range. See page 4 for more details.
Temperature Errors Zero Drift Sensitivity Drift	Temperature variation can affect the output of the sensor as described below: If the device is mounted to a level surface in the zero position, this value is the maximum drift of the output angle per °C change in temperature. When the temperature changes there is a change in sensitivity of the sensor's output. The error this causes in the measurement is calculated from the formula: $E_{sd} = SD \times \Delta T \times \theta$ Where: E_{sd} is the change in output (in degrees) due to sensitivity temperature change SD is the sensitivity drift specification from the above table (0.003) ΔT is the change in temperature in °C θ is the current angle of the inclinometer axis in question in degrees.
Accuracy (-10 to 60°C)	This is the maximum error between the measured and displayed value at any point in the measurement range (up to ±45°) at any temperature over the specified temperature range.
Long Term Stability	Stability depends on environment (temperature, vibration & power supply). This figure is based on being powered continuously in an ideal environment, and is independent from accuracy specifications.
Resolution (@3Hz bandwidth)	Resolution is the smallest measurable change in output.



Housing Drawing

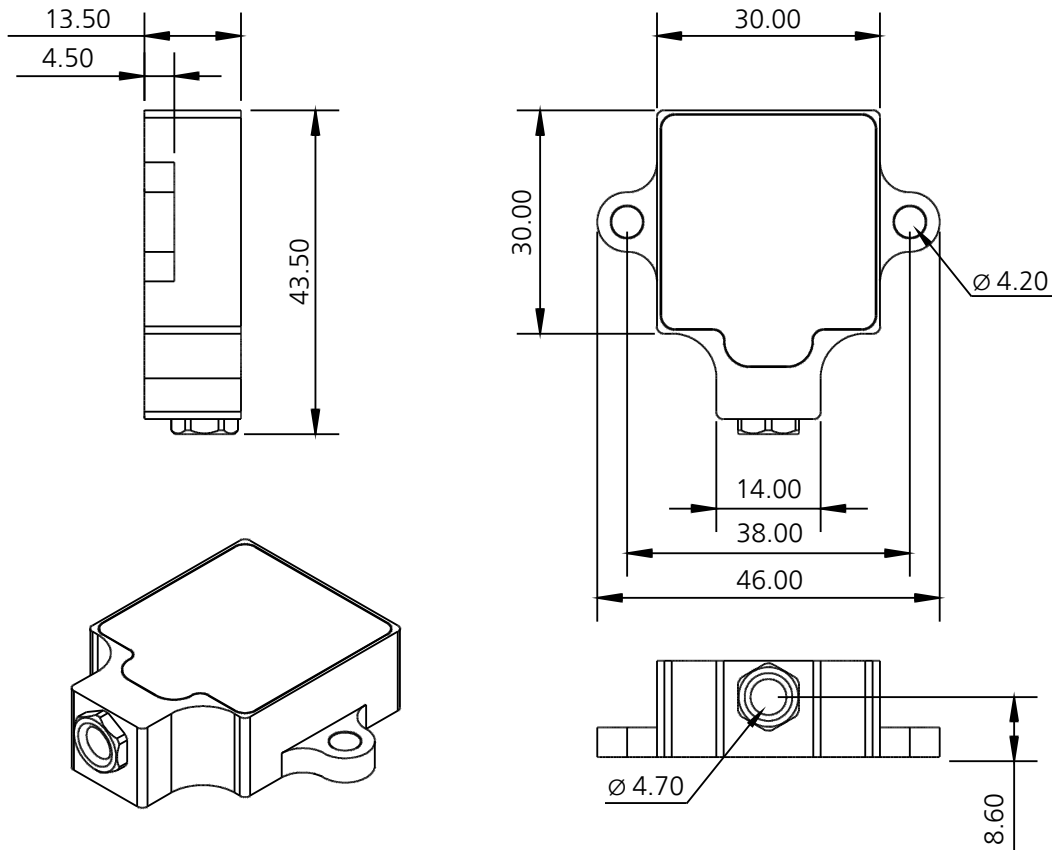

Axis Direction and Mounting Orientation and Wiring Details

Horizontal surface is the zero plane

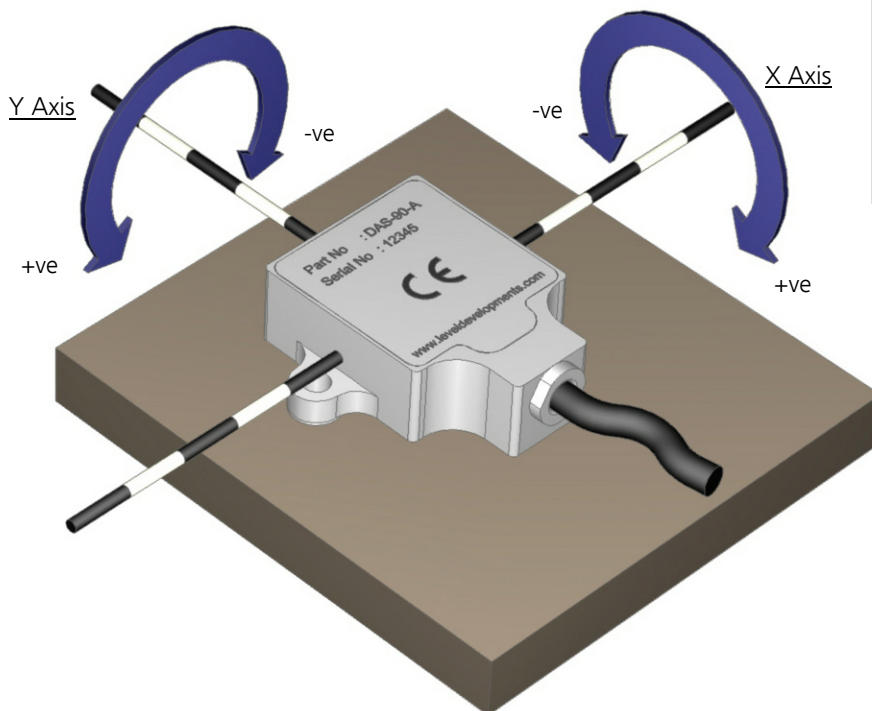

Pin #	Internal Wire Colour	Function
1	Brown	+ve Supply
2	White	Y Axis Output
3	Blue	Gnd (0V)
4	Black	X Axis Output



Voltage Output Change With Angle

All inclinometers measure a change in gravitational field to derive angle. As the inclinometer sensor is rotated, the sensing element is subject to gravitational forces which move the proof mass, and this movement is detected and converted to a voltage. In this sensor the output is linear with the change in acceleration (g), which means that the output is a Sine function of the change in angle (°). The graphs below show the output voltage vs. angle.

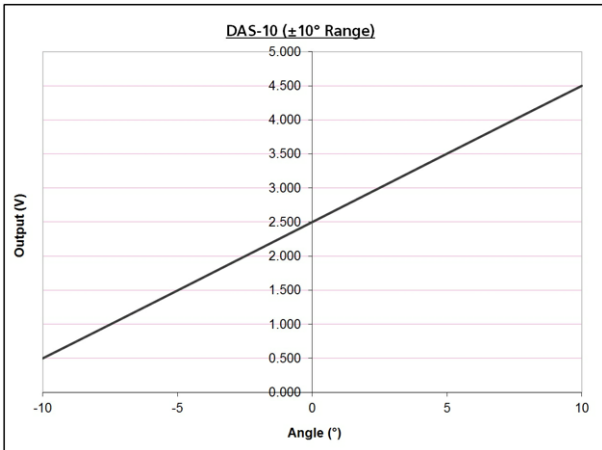

The formula to calculate the angle from the voltage is given by :

$$Angle = \sin^{-1} \left(\frac{(V_{out} - V_{offset})}{Sensitivity} \right)$$

Where :

V_{out} = Measured voltage from the sensor

V_{offset} = Measured voltage from the sensor when the sensor is at 0° (usually 2.5V)

Sensitivity = Sensitivity of the device [V/g] (see specification table on page 2)

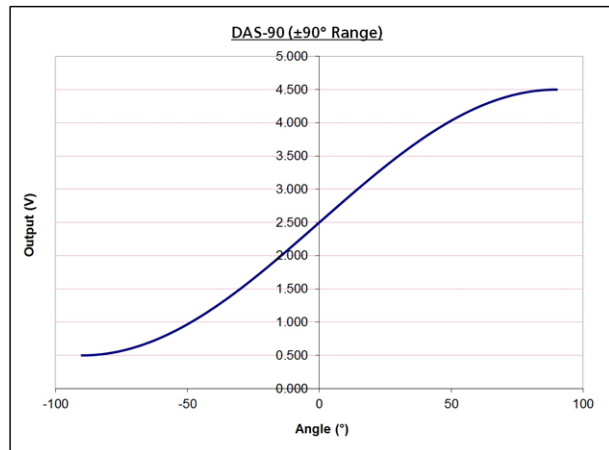
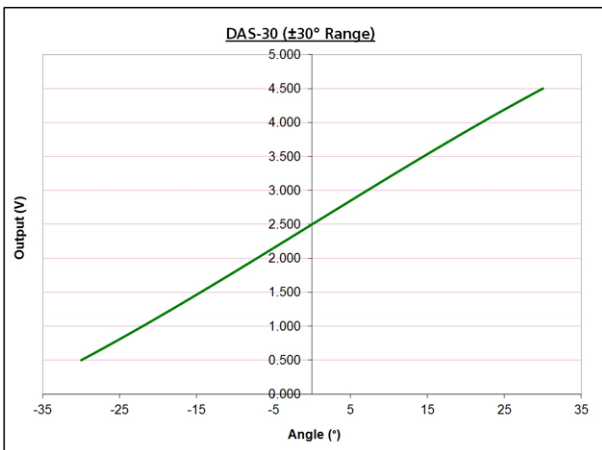

The output is very linear around the zero position, for example at ±10° the sine non linearity would only introduce an error of 0.05°. As the angle approaches 90° the sensitivity of the sensor drops significantly making measurements up to the full 90 degree range much less accurate.

Part Numbering



Series Prefix

- 10 - ±10° Full Scale Measurement Range
- 30 - ±30° Full Scale Measurement Range
- 90 - ±90° Full Scale Measurement Range

- A - 7V to 32V Input supply range
- R - 5V Input supply only.

Customer Specific Options



Cable and Connector Details

Parameter	Value
Connector description	M12 4-pin male
Connector make-up	Over-moulded
Coding	A-coded
Overall length	2 meters
Connector seal rating	IP67
Braided	Yes
Braid type	Tin plated Copper
Jacket material	PUR
Jacket diameter	4.7mm (max)
Wire Gauge	24 AWG
Conductor strands	41x0.08mm

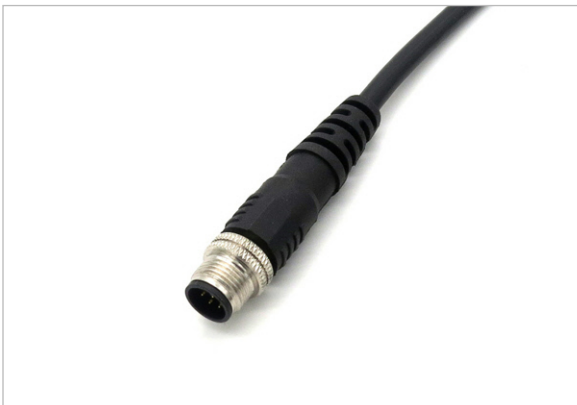

Pin Number	Internal Wire Colour	Function
1	Brown	+ve Supply
2	White	Y Axis Output
3	Blue	Gnd (0V)
4	Black	X Axis Output

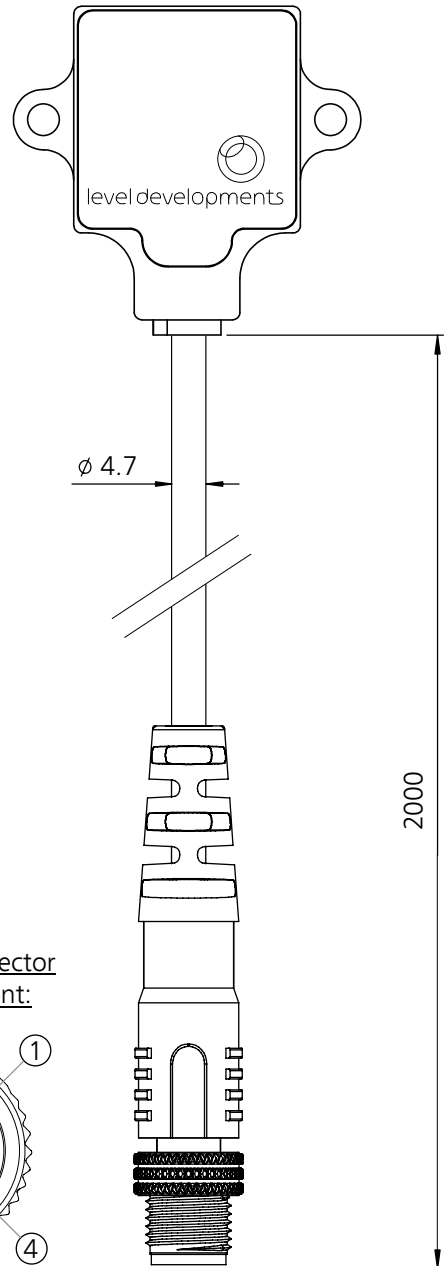

M12 male connector
View from front:

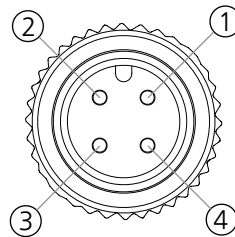

Certification

The products are type approved in accordance with the following directive(s):

EMC Directive 2004/108/EC

And it has been designed, manufactured and tested to the following specifications:

BS EN61326-1:2013

BS EN55011:2016, Group 1, Class B

Certification is available on request.

