

DIGITAL PANEL METER

A1000



■ Features

- Low cost
- Bright LED 14.2mm (red)
- AC power and DC power available

Input Specifications

■ DC Voltage, current

· DC voltage measurement (Range 11 to 14)

Range	Measurement Range	Input Impedance	Input Protection	Accuracy (23°C±5°C, 35 to 85%)
11	±199.9mV	100M	±100V	± (0.3% of F.S)
12	±1.999V			
13	±19.99V	1M	±250V	
14	±199.9V		±150V	

· DC current measurement (Range 23 to 25)

Range	Measurement Range	Input Resistance	Input Protection	Accuracy (23°C±5°C, 35 to 85%)
23	±19.99mA	10	±150mA	± 0.5% of F.S
24	±199.9mA	1	±500mA	
25	±1.999A	0.1	±3A	

■ AC Voltage, current

· AC voltage measurement (Range 12 to 14 Average)

Range	Measurement Range	Input Impedance	Input Protection	Accuracy (23°C±5°C, 35 to 85%)
12	1.999V	1M	50V	± 0.5% of F.S
13	19.99V		50V	
14	199.9V		500V	

Input Frequency: 40 Hz to 100Hz

Rectifier Circuit : Represents effective value of sine wave by demodulation of mean value

Response time: approx 1 sec (10 to 90%)

· AC current measurement (Range 23 to 26 Average)

Range	Measurement Range	Input Resistance	Input Protection	Accuracy (23°C±5°C, 35 to 85%)
23	19.99mA	10	150mA	± 1.0% of F.S
24	199.9mA	1	500mA	
25	1.999A	0.1	3A	
26	5A	1	8A	

Input Frequency: 40 Hz to 100Hz

Rectifier Circuit : Represents effective value of sine wave by demodulation of mean value

Response time: approx 1 sec (10 to 90%)

■ Thermocouple (Range KC, JC)

Range	Sensor Type	Measurement Range	Max Resolution	Accuracy (23°C±5°C, 35 to 85%)
KC	K	0 to +1000°C	1°C	± 0.8% of F.S
JC	J	0 to +400°C	1°C	

Sensor lead Resistance: less than 50

Burn out: Flash -1999

Over input voltage: ±5VDC

Cold Junction Compensator Accuracy: ±2° C

■ RTD (Pt100) (Range PA, PJ)

Range	Sensor Type	Measurement Range	Max Resolution	Accuracy (23°C±5°C, 35 to 85%)
PA	Pt100	-100.0 to +199.9°C	0.1°C	± 0.2% of F.S
PJ	Pt100	-200 to +600°C	1°C	± 0.4% of F.S

Current for resistance : 1mA (TYP)

External lead resistance: less than 1 ohm per lead

■ Process (Range 1V, 2A)

Range	Measurement Range	Display	Input Impedance	Input Protection	Accuracy (23°C±5°C, 35 to 85%)
1V	1 to 5V	offset ±1000	1M	±100V	± 0.3% of F.S
2A	4 to 20mA	fullscale ±100 to 1999	51	50mA	± 0.4% of F.S

■ Common Specification

Input bias current: 50 pA (TYP)

Sampling speed: 2.5/sec

Over range indication: When input exceeds the maximum display flash 1999

Max. display: 1999

Display: Red LED 14.2mm height

Dimensions: 96mm (H) X 48mm (W) X 75mm (D) DIN size

Power supply: 90 to 132 VAC

180 to 264 VAC

5 to 24 VDC

Power Consumption: 1.5 VA at AC power

100mA at DC power

Operating Temp.: 0 to 50° C, 35 to 85%RH

Storage Temp.: -10 to 70° C less than 60% RH

Dielectric Strength: Power supply and input, 1500 VAC/1min at AC power

Power supply and input, 500 VDC/1min at DC power

Insulation Resistance : 500 VDC 100M at above terminals

DIGITAL PANEL METER

A1000

Model Code

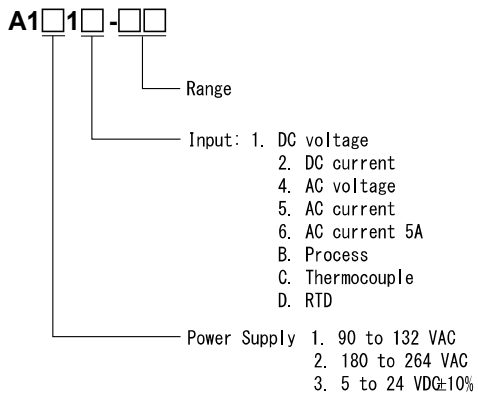

Dimensions

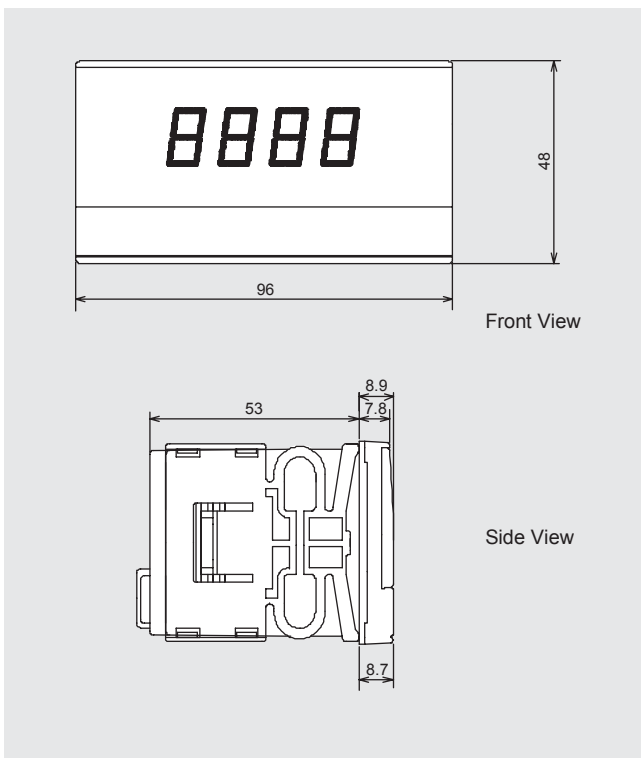

Connection Diagram

