

CS1210 Reaction Torquemeter

SPECIFICATIONS

- Range from ± 160 to $\pm 10,000$ Nm ($\pm 1 \pm 8,000$ lbf.ft)
- Collar mechanical fittings
- Stainless Steel or Aluminum
- Gland or Connector Output
- Built In Amplifier per Request

The **CS1210** Series has been developed to measure torque in static applications. The mechanical design and gauge placement minimizes transverse effects.

Fitted with metallic strain gauges in a Wheatstone bridge circuit, the **CS1210** is providing excellent temperature stability. For high-level output a model with integrated amplifier is available.

With a long standing experience as a designer and manufacturer of sensors, TE CONNECTIVITY often works with customers to design or customize sensors for specific uses and testing environments.

On request, Instruction documents can be provided to ease the selection and use of our sensors and provide helpful tips.

FEATURES

- For Static Applications
- High Stiffness
- Collar Mechanical Fittings
- High Level Output Model with Integrated Amplifier

APPLICATIONS

- Process control equipment
- Torque fatigue test benches
- Robotics and effectors
- Bearing torque measurement
- Laboratory and Research

STANDARD RANGES

Range in Nm (FS)	160	300	600	1,2k	2,4k	3,5k	4,8k	7k	10k
Range in lbf.ft (FS)	128	240	480	960	1,92k	2,8k	3,84k	5,6k	8k
Stiffness in Nm/rad	3.5x10 ⁴	6x10 ⁴	2x10 ⁵	3.5x10 ⁵	1x10 ⁶	1.4x10 ⁶	2.3x10 ⁶	3.4x10 ⁶	5.7x10 ⁶
Stiffness in lbf.ft/rad	2.4x10 ³	1.4x10 ⁴	1.4x10 ⁴	2.4x10 ⁴	6.9x10 ⁴	1x10 ⁵	1.6x10 ⁵	2.3x10 ⁵	3.9x10 ⁵
Material	Aluminum Alloy			Stainless Steel					

PERFORMANCE SPECIFICATIONS (typical values at temperature 23±3°C)

Parameters	
Operating Temperature Range (OTR)	-20 to 80° C (-4 to 176° F)
Compensated Temperature Range (CTR)	0 to 60° C (32 to 140° F)
Zero Shift in CTR	<0.5% F.S./ 50 ° C [/100° F]
Sensitivity Shift in CTR	<1% of reading / 50° C [/100° F]
Over-Range	
Without Damage	1.5 x F.S.
Accuracy	
Combined Non-Linearity & Hysteresis	±0.25%F.S.

Electrical Characteristics

Model	CS1210¹	CS1210-A1	CS1210-A2
Supply Voltage	1 to 10Vdc regulated	10 – 30Vdc	±15Vdc (±12 to ±18Vdc)
Sensitivity "FSO" ²	±2mV/V	±2V ±0.2V	±5V ±0.2V
Zero Offset ²	<±1mV	2.5V ±0.2V	0V ±0.2V
Input Impedance/Consumption	350 to 700Ω	<50mA	<50mA
Output Impedance	350 to 700Ω	1 kΩ ⁵	1 kΩ ⁵
Insulation under 50Vdc	≥100MΩ	≥100MΩ	≥100MΩ

Notes

1. Sensors are calibrated with 10Vdc power supply as standard.
2. Signal goes positive in CW strain with standard wiring configuration. Other signal output on request
3. Electrical Termination: Connector output including mate
4. Material: Body in stainless steel or aluminum alloy
5. Output impedance < 100Ω on request
6. CE conformance according to EN 61010-1, EN 50081-1, EN 50082-1

DIMENSIONS & WIRING SCHEMATIC (IN METRIC AND IMPERIAL)

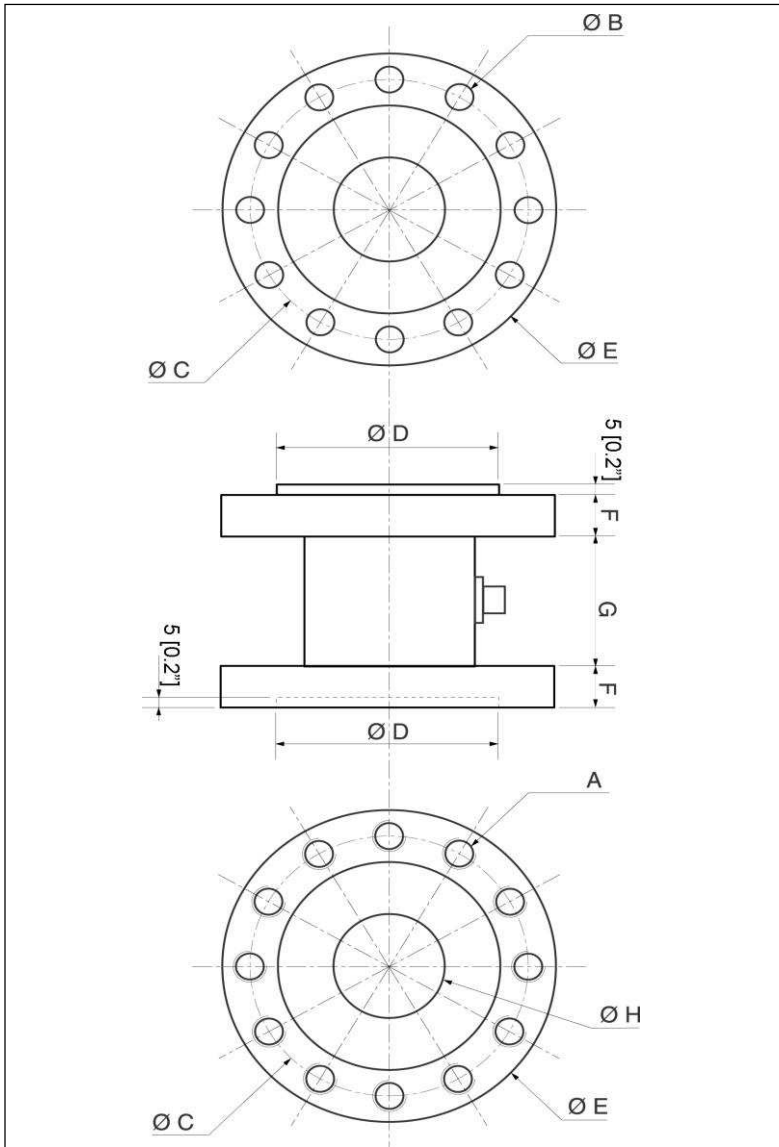

Wiring Schematic

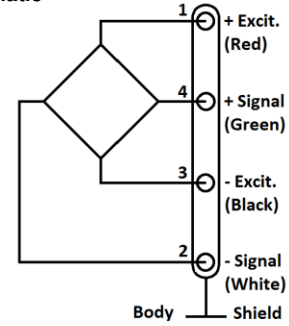

Version -A1

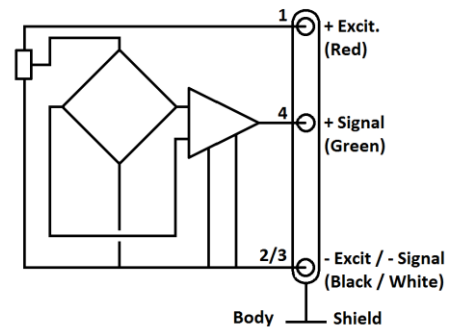

Version -A2

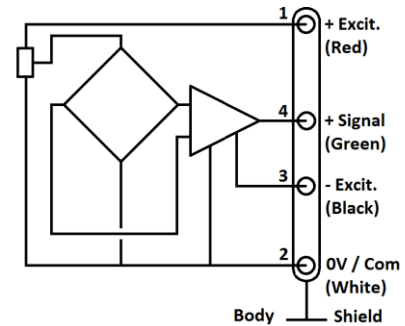

Dimensions in mm [inch]

F.S. in Nm [lbf.ft]	160 - 300 [128 - 240]	600 [480]	1,2k [960]	2,4k [1,92k]	3,5k [2,8k]	4,8k [3,84k]	7k [5,6k]	10k [8k]
A	12 x M10	12 x M10	12 x M10	12 x M12	12 x M16	12 x M18	12 x M20	12 x M24
B	12 x \varnothing 10.3	12 x \varnothing 10.3	12 x \varnothing 10.3	12 x \varnothing 12.3	12 x \varnothing 16.3	12 x \varnothing 18.3	12 x \varnothing 20.5	12 x \varnothing 24.5
C	100 [3.94]	100 [3.94]	100 [3.94]	125 [4.92]	160 [6.30]	180 [7.09]	215 [8.46]	235 [9.25]
D	80 [3.15]	80 [3.15]	80 [3.15]	90 [3.54]	120 [4.72]	140 [5.51]	160 [6.30]	180 [7.09]
E	118 [4.65]	118 [4.65]	118 [4.65]	148 [5.83]	186 [7.32]	218 [8.58]	248 [9.76]	272 [10.71]
F	15 [0.59]	15 [0.59]	15 [0.59]	15 [0.59]	15 [0.59]	15 [0.59]	20 [0.79]	20 [0.79]
G	45 [1.77]	45 [1.77]	45 [1.77]	48 [1.89]	52 [2.05]	55 [2.17]	60 [2.36]	60 [2.36]
H	30 [1.18]	45 [1.77]	45 [1.77]	70 [2.76]	85 [3.35]	100 [3.94]	110 [4.33]	130 [4.33]

OPTIONS

A1 : Amplified Tension output with unipolar power supply
A2 : Amplified Tension output with bipolar power supply
ET1 : CTR -20 to 100° C [-4 to 212° F] OTR=CTR
ET3 : CTR -40 to 150° C [-40 to 302° F] OTR=CTR (Note : ET3 not available with A1 and A2 options)
V00 : Non-standard power supply calibration, replace "00" with value in Volt (standard 10Vdc, unamplified sensor only)
PE : Cable Gland Termination with 2 m [6.6 ft] cable

ORDERING INFORMATION

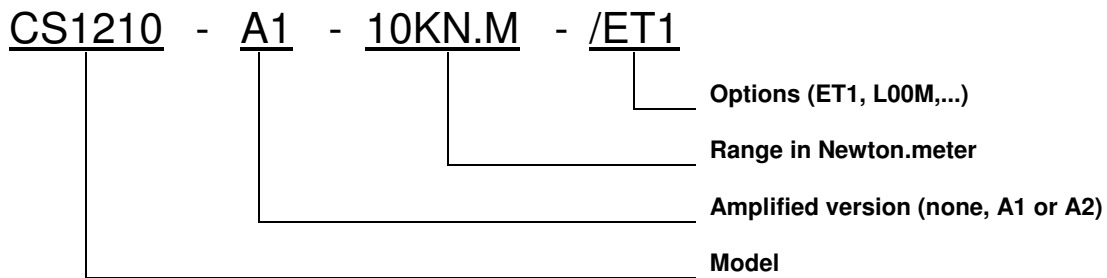

SUPPLIED ACCESSOIRES

EFMX-7M : mating plug Jaeger 530-272-006 with clamp 530-371-006 for standard and ET1
EFMX-7H : mating plug Jaeger 530-604-006 with clamp 530-693-006 for ET2 or ET3 option

NORTH AMERICA

Measurement Specialties, Inc.,
 a TE Connectivity company
 45738 Northport Loop West
 Fremont, CA 94538
 Tel: +1 800 767 1888
 Fax: +1 510 498 1578
customercare.frm@te.com

EUROPE

MEAS France SAS,
 a TE Connectivity company
 26 Rue des Dames
 78340 Les Clayes-sous-Bois, France
 Tel: +33 (0) 130 79 33 00
 Fax: +33 (0) 134 81 03 59
customercare.lcsb@te.com

ASIA

Measurement Specialties (China) Ltd.,
 a TE Connectivity company
 No. 26 Langshan Road
 Shenzhen High-Tech Park (North) Nanshan
 District, Shenzhen, 518057
 China
 Tel: +86 755 3330 5088
 Fax: +86 755 3330 5099
customercare.shzn@te.com

TE.com/sensorsolutions

Measurement Specialties, Inc., a TE Connectivity company.

Measurement Specialties, TE Connectivity, TE Connectivity (logo) and EVERY CONNECTION COUNTS are trademarks. All other logos, products and/or company names referred to herein might be trademarks of their respective owners.

The information given herein, including drawings, illustrations and schematics which are intended for illustration purposes only, is believed to be reliable. However, TE Connectivity makes no warranties as to its accuracy or completeness and disclaims any liability in connection with its use. TE Connectivity's obligations shall only be as set forth in TE Connectivity's Standard Terms and Conditions of Sale for this product and in no case will TE Connectivity be liable for any incidental, indirect or consequential damages arising out of the sale, resale, use or misuse of the product. Users of TE Connectivity products should make their own evaluation to determine the suitability of each such product for the specific application.

© 2015 TE Connectivity Ltd. family of companies All Rights Reserved.