



Features

- Dual axis measurement from $\pm 5^\circ$ to $\pm 30^\circ$
- High resolution and accuracy
- Low temperature drift, with optional temperature compensation to further improve temperature performance.
- RS232 output interface
- High precision analogue 0-5V, 0.5-4.5V, 0-10V and 4-20mA output options
- Robust corrosion resistant anodised Aluminium housing with IP67 sealing
- IP67 Sealed locking M9 connector or cable gland with fixed cable
- Outputs isolated from supply
- CE certified and RoHS compliant.



Description

The VS series inclinometers are high performance inclination sensors designed for use in the toughest environments. There are a wide range of options to cover a measurement range from $\pm 5^\circ$ to $\pm 30^\circ$. The robust anodised Aluminium housing is sealed to IP67 and utilises high performance sealed locking M9 connectors. It has an RS232 digital interface, as well as a factory configurable analogue voltage or current output. The

device has inherently good temperature stability, but this can be improved further with optional temperature compensation over a range of different temperatures. The devices are CE certified and RoHS compliant. These devices are manufactured and calibrated in our UK factory to guarantee performance to the stated specification, and are built and configured to order on short lead times.

General Specifications

Parameter	Value	Unit	Notes
Supply Voltage	12-30	V dc	Supply is isolated with high performance DC-DC converter, filtered, suppressed and regulated internally, however we recommend the use of a low noise supply to prevent noise coupling to the sensor.
Operating Current	30 60	mA mA	At 24V supply (RS232 only and analogue voltage models) At 12V supply (RS232 only and analogue voltage models) Supply current increases for 4-20mA output devices by 1.5 x output current
Output Isolation	1500	Vdc	Outputs are isolated from supply internally with high performance DC-DC conv.
Operating Temperature	-40 to 85	°C	Maximum operating temperature range. Units can be calibrated between -20 and 70°C on request.
RS232 Output Rate	38400	bps	Bit rate is adjustable between 115.2k, 57.6k, 38.4k, 19.2k, 9.6k, 4.8k and 2.4k via the digital interface
RS232 Data Format	38.4, 8,1,n		1 start bit, 8 data bits, 1 stop bit, no parity
Filter Frequency	0.5	Hz	This is the frequency of the internal low pass filter applied to the sensor. It is adjustable between 8Hz and 0.125Hz via the RS232 control commands.
Mechanical shock	5000	G	Shock survival limit for internal sensor 5000G for 0.5ms
Weight	190	g	Not including cable
Sealing	IP67	-	Seal rating applies to housing and connectors and cable assemblies.



Performance Specifications

Parameter	VS-05	VS-10	VS-15	VS-30	Unit
Measuring range	±5	±10	±15	±30	°
Zero Bias Error	±0.01	±0.01	±0.015	±0.02	°
Accuracy (@20°C)	±0.015	±0.02	±0.03	±0.04	°
Temperature Errors (without compensation)					
Zero Drift	±0.002	±0.002	±0.002	±0.002	°/°C
Sensitivity Drift	±0.004	±0.004	±0.004	±0.004	%/°C
Temperature Errors (with compensation)					
Zero Drift	±0.0005	±0.0005	±0.0005	±0.0005	°/°C
Sensitivity Drift	±0.0008	±0.0008	±0.0008	±0.0008	%/°C
Accuracy -10 to 60°C (without compensation)	±0.1	±0.13	±0.15	±0.18	°
Accuracy -10 to 60°C (with compensation)	±0.04	±0.05	±0.06	±0.07	°
Long Term Stability	±0.01	±0.01	±0.01	±0.01	°
Resolution (@1Hz BW)	0.001	0.001	0.001	0.001	°

Parameter	Notes
Measuring range	Defines the calibrated measurement range. Direction of measurement can be reversed and zero position can be reset anywhere in range. Settings are stored in non volatile memory so are remembered after power down.
Zero Bias Error	This is the maximum angle from the device when it is placed on a perfectly level surface. The zero bias error can be removed from measurement errors either by mechanical adjustment, or as a fixed offset value after installation, or by using the 'setzcur' command to zero the device (see page 8)
Accuracy (@20°C)	This is the maximum error between the measured and displayed value at any point in the measurement range when the device is at room temperature (20°C). This value includes all forms of errors including non-linearity and cross axis errors.
Temperature Errors	Two sets of specifications, one for un-compensated devices and one for temperature compensated devices (where the accuracy needs to be maintained over a wider temperature range). See part numbering options on page 7.
Zero Drift	If the device is mounted to a level surface in the zero position, this value is the maximum drift of the output angle per °C change in temperature.
Sensitivity Drift	When the temperature changes there is a change in sensitivity of the sensor's output. The error this causes in the measurement is calculated from the formula: $E_{sd} = SD \times \Delta T \times \theta$ Where: E_{sd} is the change in output (in degrees) due to sensitivity temperature change SD is the sensitivity drift specification from the above table (0.014% or 0.005%) ΔT is the change in temperature in °C θ is the current angle of the inclinometer axis in question in degrees.
Accuracy -10 to 60°C (without compensation)	This is the maximum error between the measured and displayed value at any point in the measurement range at any temperature over the specified temperature range without individual temperature compensation.
Accuracy -10 to 60°C (with compensation)	This is the maximum error between the measured and displayed value at any point in the measurement range at any temperature over the calibrated temperature range with individual temperature compensation.
Long Term Stability	Stability depends on environment (temperature, shock, vibration and power supply). This figure is based on being powered continuously in an ideal environment.
Resolution (@1Hz bandwidth)	Resolution is the smallest measurable change in output.



Housing Drawing - Connector Version

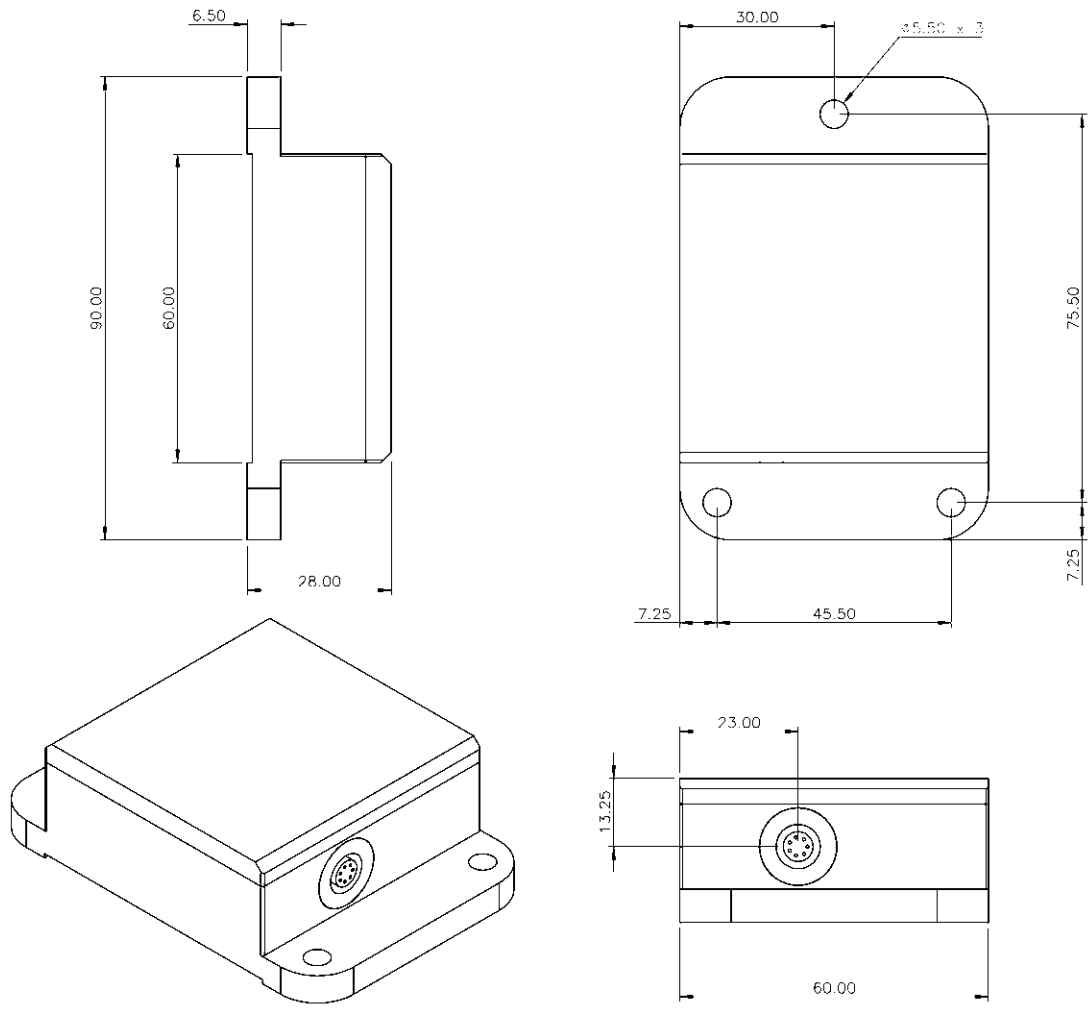

Axis Direction and Mounting Orientation - Connector Version

Mounted on Horizontal Surface

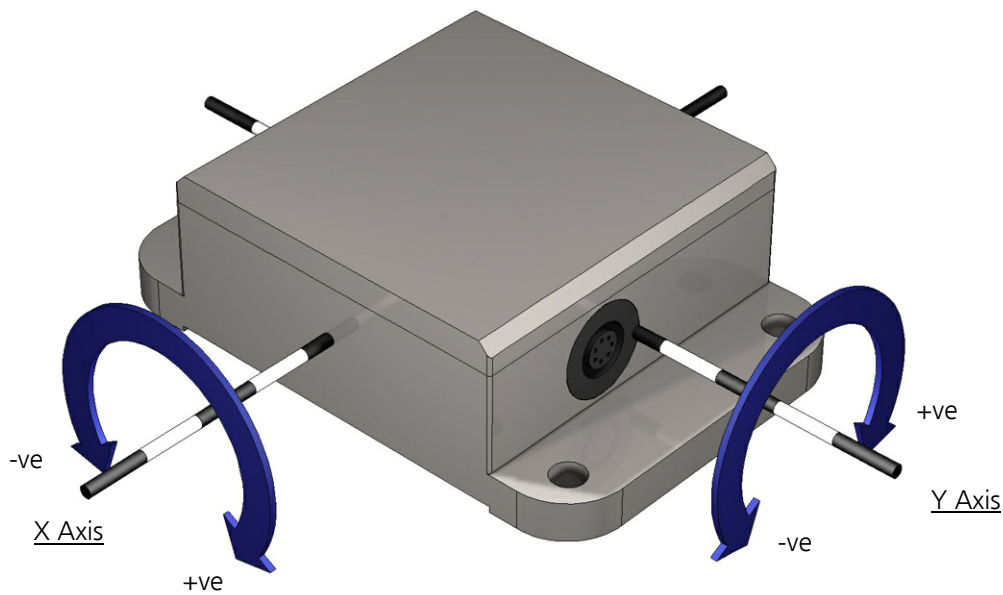



Housing Drawing - Cable and Gland Version

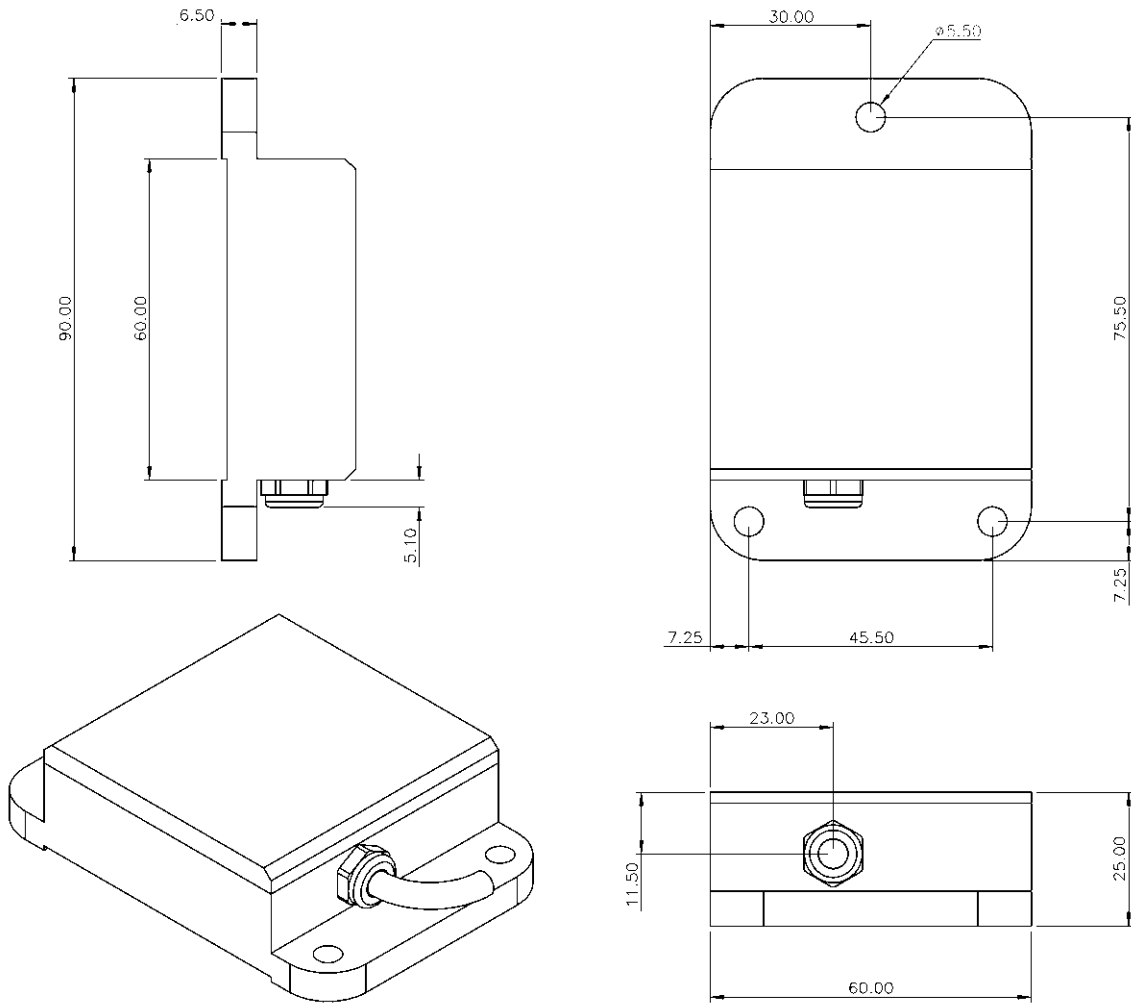

Axis Direction and Mounting Orientation - Cable and Gland Version

Mounted on Horizontal Surface

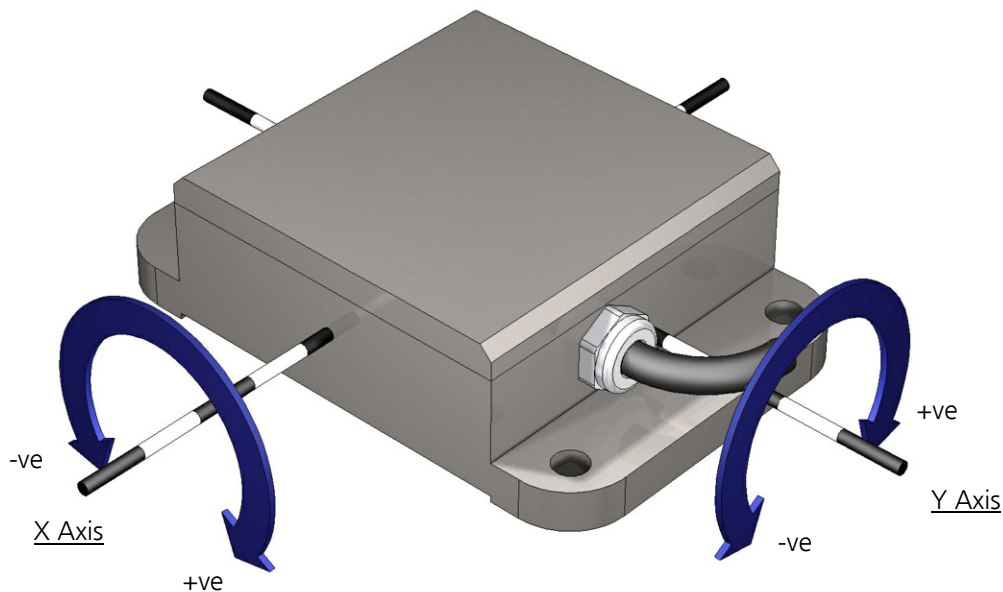



Analogue Output Change With Angle

All inclinometers measure a change in the effect of gravitational field on a mass to derive angle. As the inclinometer sensor is rotated, the sensing element is subject to gravitational forces which move the proof mass. The signal generated by this movement is measured and through a digital signal processor the response is linearised and then sent to the output interface. In the VS series, there is an RS232 interface on all devices, and an optional analogue voltage or current output (see page 7 for output options).

0 to 5V Analogue Voltage Output

$$\text{Angle} = (V_{\text{out}} - 2.5) \times \left(\frac{\text{Range}}{2.5} \right)$$

0.5 to 4.5V Analogue Voltage Output

$$\text{Angle} = (V_{\text{out}} - 2.5) \times \left(\frac{\text{Range}}{2} \right)$$

0 to 10V Analogue Voltage Output

$$\text{Angle} = (V_{\text{out}} - 5) \times \left(\frac{\text{Range}}{5} \right)$$

4 to 20mA Analogue Current Output

$$\text{Angle} = (I_{\text{out}} - 12) \times \left(\frac{\text{Range}}{8} \right)$$

Where :

Angle = The angle of the device in degrees

V_{out} = Measured voltage from the sensor in Volts

I_{out} = Measured current from the sensor in mA

Range = Measuring range of the device. For example for a ±30° device, the range is 30.

The analogue output is generated by a 16 bit high performance Digital to Analogue converter (DAC) with an effective resolution of better than 0.001°. The output accuracy of the DAC is within 0.01% of the value obtained from the RS232 digital interface, and the temperature coefficient is 2ppm / °C

Certification

The products are type approved to in accordance with the following directive(s):

EMC Directive 2004/108/EC

And it has been designed, manufactured and tested to the following specifications:

BS EN61326-1:2006

Electrical equipment for measurement, control and laboratory use – EMC Requirements

BS EN55011:2007, Group 1
Class B





Connector Version - Connection Details

The connection socket is a 7 pin Binder M9 panel socket. It mates with straight cable socket part number 99-0421-00-07 or right angle cable socket 99-0421-70-07. There are also a range of pre-moulded leads available.

Pin Number	Pin Function	Wire Colour
1	Power Supply +ve	Red
2	Power Supply GND	Black
3	Signal and RS232 GND	Green
4	X Axis Analogue Output	Orange
5	Y Axis Analogue Output	White
6	RS232 Transmit (Txd)	Brown
7	RS232 Receive (Rxd)	Blue

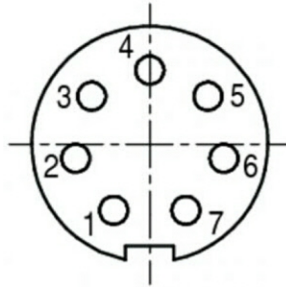

Cable And Connector Accessories



Right Angle Connector
Part # EL-CON-99-0421-70-07



Right Angle Cable, 2m, PVC
Part # EL-CAB-M9X7MRA-2



Right Angle Cable, 5m, PVC
Part # EL-CAB-M9X7MRA-5



Straight Connector
Part # EL-CON-99-0421-00-07



Straight Cable, 2m, PVC
Part # EL-CAB-M9X7MS-2



Straight Cable, 5m, PVC
Part # EL-CAB-M9X7MS-5

As well as these standard cables, custom cables can be supplied in any length up to 100m. The maximum length of cable that RS232 can transmit over depends on many factors, such as the baud rate, the method of termination, the type of cable, the surrounding electrical noise, and the type of transceiver at the other end of the cable. We have tested this device connected with a serial port of a PC at 9600bps over 100m of the screened cable in a low noise environment. All cables are shielded with a modified PVC grey jacket.



Cable Version - Connection Details

- IP67 Sealed cable gland, brass with Nickel plating.
- 24AWG Tinned copper cable, braided & foil screen.
- Black TPU jacket, overall cable diameter 5.5mm

Pin Function	Wire Colour
Power Supply +ve	Red
Power Supply GND	Black
Signal and RS232 Output GND	Green
X axis Current Output	Orange
Y axis Current Output	White
RS232 Transmit (TxD)	Brown
RS232 Receive (RxD)	Blue

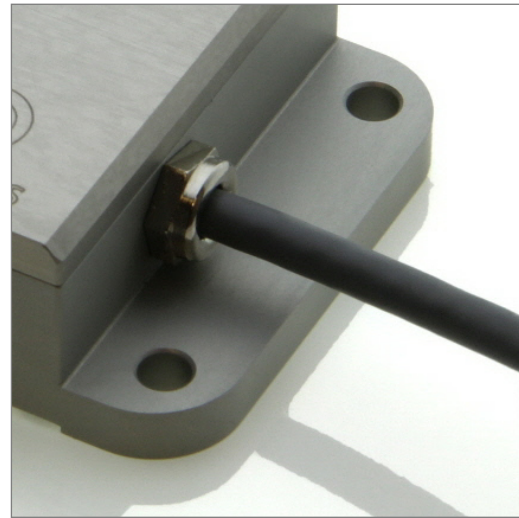

Part Numbering

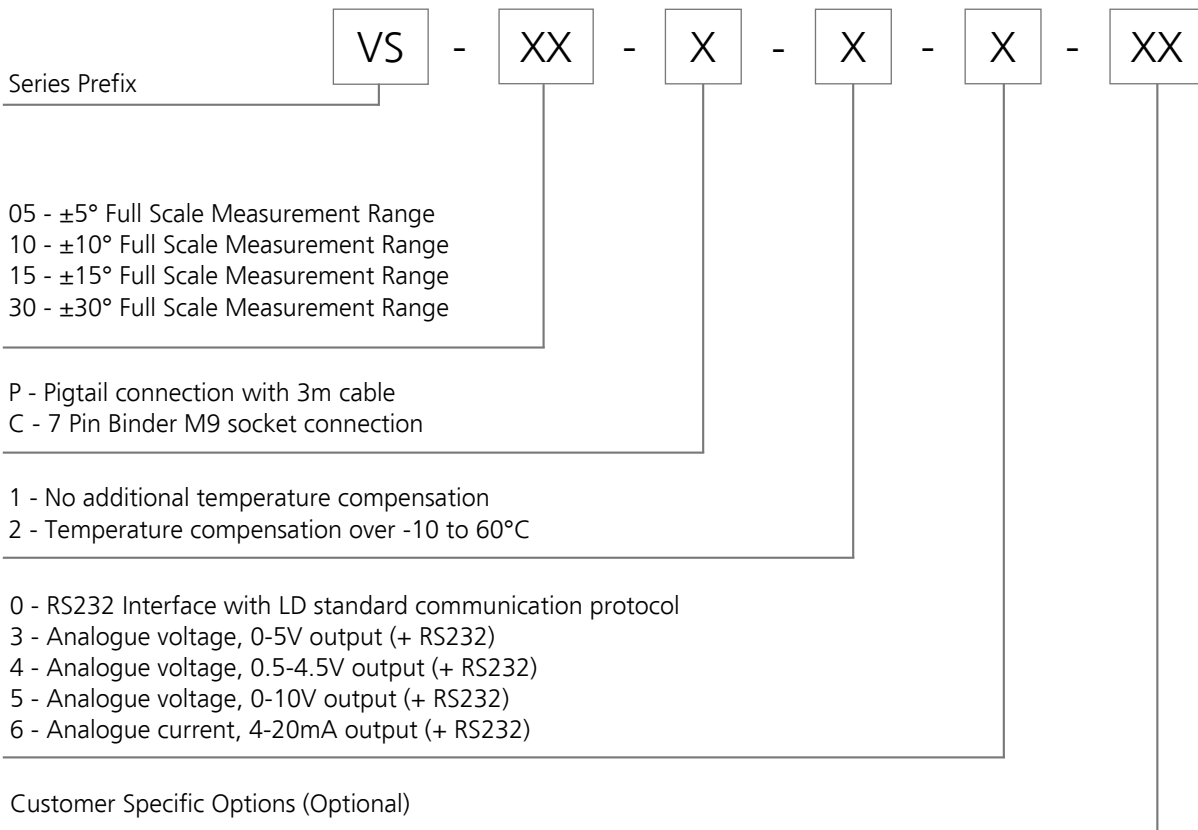

Example:

VS-15-C-2-6

VS Series dual axis inclinometer
 ±15° Full Scale Measurement Range
 Binder M9 female panel mount IP67 connector
 Temperature compensated over the range -10 to 60°C
 Dual 4-20mA current output & RS232 Output with LD standard communication protocol



Level Developments Simplified Control Command Set

Data is transmitted and received over RS232 in full duplex mode. The default configuration is with the baud rate set to 38.4kbps, with 8 data bits, 1 stop bit and no parity. All commands are lower case and 7 bytes long. The time between each character of the command must be less than 100ms otherwise the device will discard the command. The settings are all stored in non volatile memory.

Command	Description	Response Length	Response
get---x	Returns the X axis angle as either: - An INT32 value equal to the angle x 1000 - A fixed length ASCII string terminated with a carriage return depending on the setting of commands 'setoasc' or 'setoint' Shipping default is INT32.	4 bytes 9 bytes	0x XX XX XX XX +025.430<CR>
get---y	Returns the Y axis angle as either: - An INT32 value equal to the angle x 1000 - A fixed length ASCII string terminated with a carriage return depending on the setting of commands 'setoasc' or 'setoint' Shipping default is INT32.	4 bytes 9 bytes	0x YY YY YY YY +025.430<CR>
get-x&y	Returns the X and Y axis angle (X is transmitted first) as either: - A pair of INT32 value equal to the angle x 1000 - A fixed length comma separated ASCII string terminated with <CR> depending on the setting of commands 'setoasc' or 'setoint' Shipping default is INT32.	8 bytes 18 bytes	0x XX XX XX XX YY YY YY YY ±xxx.xxx,±yyy.yyy<CR>
gettemp	Returns the temperature of the sensor as either: - An INT16 value equal to the temperature x 100 - A fixed length ASCII string terminated with a carriage return depending on the setting of commands 'setoasc' or 'setoint' Shipping default is INT32.	2 bytes 6 bytes	0x XX XX ±tt.t<CR>
str9999	Set continuous output transmission rate in milliseconds (50-9999ms) - str0100 - 100ms (0.1s) between transmissions	2 bytes	OK
setcasc	Sets the output to transmit the X and Y angle continuously in ASCII format at the rate defined by strXXXX.	18 bytes	±xxx.xxx,±yyy.yyy<CR>
stpcasc	Stops the continuous transmission of ASCII data	2 bytes	OK
get-flt	Returns the value of the current filter time constant in ms as an INT16	2 bytes	0x XX XX
setdir1 setdir2 setdir3 setdir4	Sets the X axis measurement direction to positive clockwise Sets the X axis measurement direction to negative clockwise Sets the Y axis measurement direction to positive clockwise Sets the Y axis measurement direction to negative clockwise	2 bytes	OK
setzcur	Tare function to set the current position to zero	2 bytes	OK
setzfac	Cancels tare function and resets zero to factory setting	2 bytes	OK
setoasc	Sets the output to ASCII format	2 bytes	OK
setoint	Sets the output to Integer format	2 bytes	OK
setflt1 setflt2 setflt3 setflt4 setflt5 setflt6 setflt7	Sets the digital filter frequency response to 0.125Hz Sets the digital filter frequency response to 0.25Hz Sets the digital filter frequency response to 0.5Hz Sets the digital filter frequency response to 1Hz Sets the digital filter frequency response to 2Hz Sets the digital filter frequency response to 4Hz Sets the digital filter frequency response to 8Hz	2 bytes	OK
set-br1 set-br2 set-br3 set-br4 set-br5 set-br6 set-br7	Sets the BAUD rate to 2400bps Sets the BAUD rate to 4800bps Sets the BAUD rate to 9600bps Sets the BAUD rate to 19200bps Sets the BAUD rate to 38400bps Sets the BAUD rate to 57600bps Sets the BAUD rate to 115200bps	2 bytes	OK
sar####	Scales the Analogue output signal to the specified range where #### is equal to the range in degrees. The configurable range is 1 to 90: - sar1.00 - Sets the 4-20 output range to ±1° - sar90.0 - Sets the 4-20 output range to ±90° The default setting is based on the ordered part, e.g. VS-05-C-1-6 will be shipped with the output signal scaled to ±5°. (Note: accuracy cannot be guaranteed outside of the calibration range of the part number purchased).	7 bytes	XX.X<CR> OK



Software

A free Windows based application for reading angle, logging and device configuration is available from our website. It requires Windows XP SP3, Windows 7 or Windows 8, and works with 32 and 64 bit systems. It also requires the .net framework V3.5 or higher, and will prompt you to download and install this from Microsoft if it is not already installed on your system. A COM port is also required, and can either be a built in COM port, or a USB to Serial COM port.

The basic features are shown below:

- Automatic or manual configuration of COM port parameters
- Compatible with single or dual axis sensors
- Adjustable number of decimal places on displays
- Logging of data at specified intervals into CSV file
- Setting device to absolute or relative measurement mode
- Switching the data transfer protocol between Integer and ASCII
- Changing the frequency response of the sensor
- Changing the Baud rate of the sensor

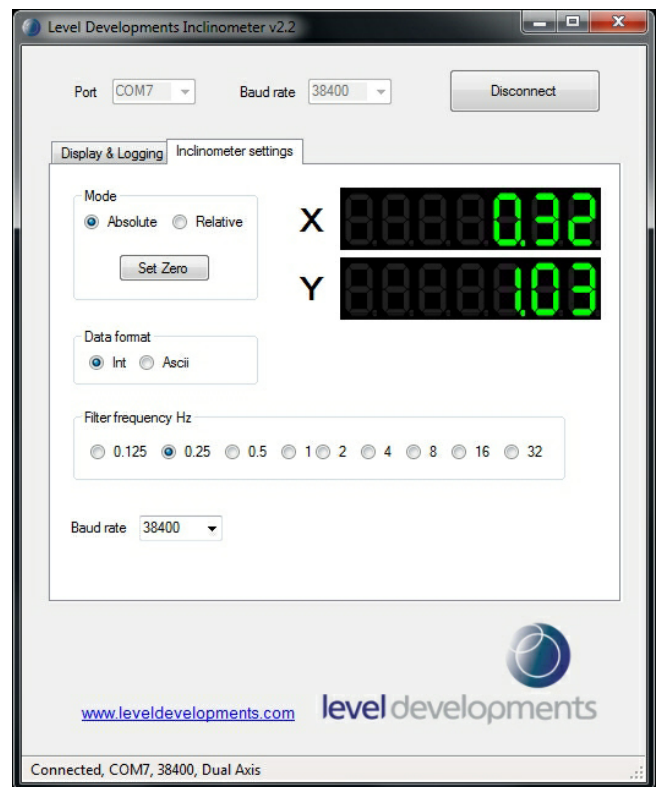
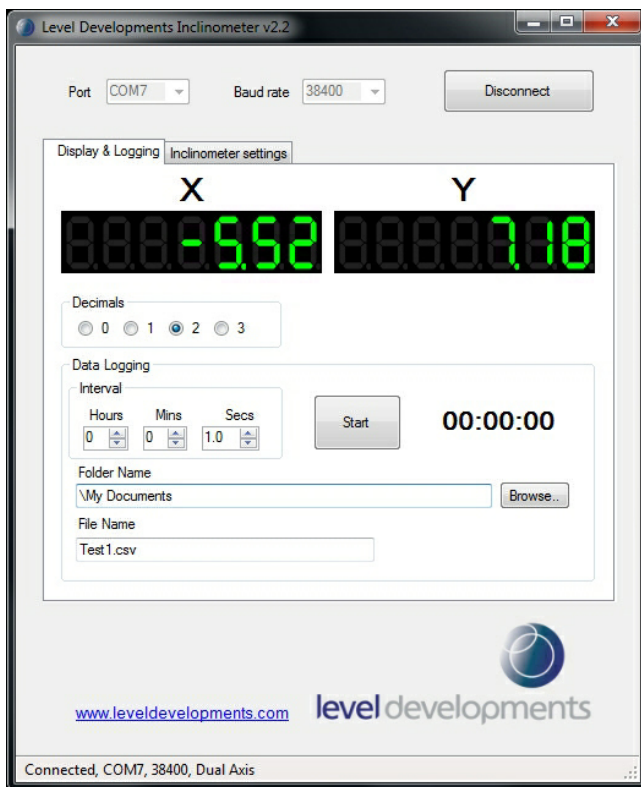

We can also offer custom software development services, please contact us for further information.

This software is provided 'as-is', without any express or implied warranty. In no event will the authors be held liable for any damages arising from the use of this software.