



# TYRE INFRARED TEMPERATURE SENSOR INFKL-150

## Aluminium housing

**Dimensions** 20 x 18 x 12 mm

**Weight** 26 g

<b>Range</b>	150°C
<b>Supply</b>	5 Volts
<b>Output</b>	0.4 V to 4.9 V
<b>Sensitivity Signal</b>	30 mV/°C 0.4 V at 0°C 4.6V at 140°C
<b>Accuracy</b>	2.5% FS
<b>Response time</b>	100 ms
<b>Supply current</b>	1.5 mA

<b>IR Wave length</b>	8 to 14 µm
<b>Emissivity</b>	99%
<b>Calibrator</b>	Land P550P
<b>Protection</b>	IP 64
<b>Vibration Test</b>	20 Gpp 5'
<b>Shocks</b>	1000 G
<b>Operating temperature</b>	0 to 40°C
<b>Storage Temperature</b>	-40 to + 125°C

**Measurement distance :** 30 to 70 mm

**Field of view :** 2.5 : 1

**Spot size :** 20mm diameter at 50mm distance

**Connection :** 1 meter of 3 x AWG26 PTFE shielded cable

**Connector :** without

Couleur Fil	Fonction	Contact / Pin
Rouge / Red	5 V	
Blanc / White	Signal	
Bleu / Blue	0 V	

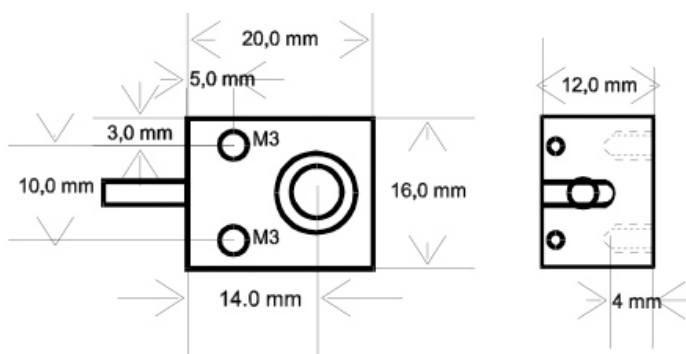
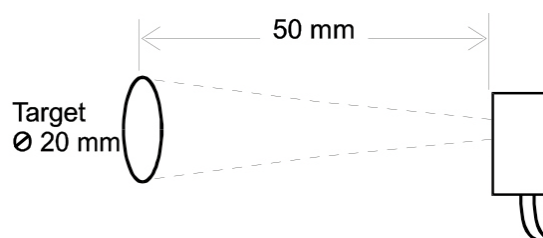

**TEXYS  
INTERNATIONAL**

ZA des Chamonds  
Rue Edouard Branly  
58640 Varennes-Vauzelles  
(FRANCE)

Tel. : +33 (0) 3 86 21 27 18

Fax : +33 (0) 3 86 21 24 49