

尺寸及量程 / Size and Capacity

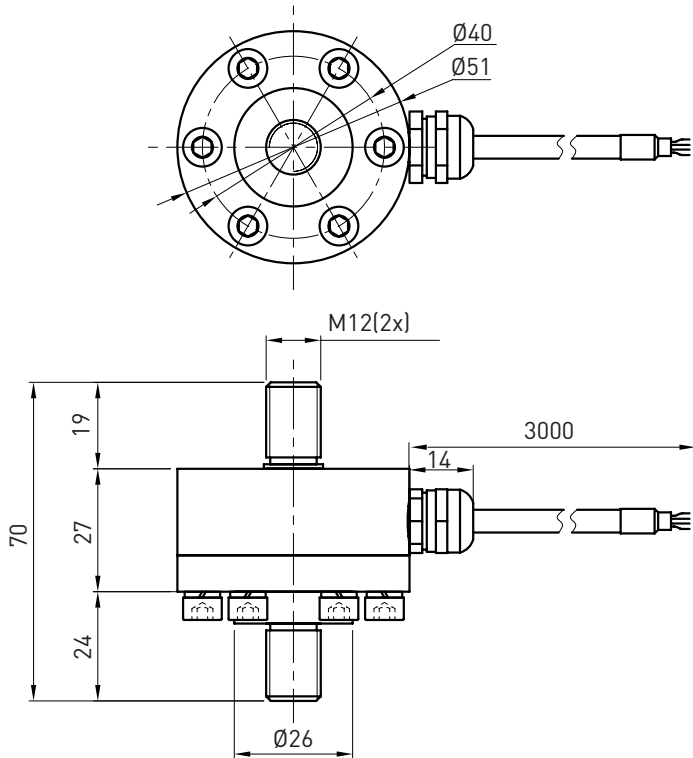

量程 /Capacity (KN)	材料 /Material	重量 /Weight
1/2/5/10/20	不锈钢 /Stainless steel	0.6kg

技术参数 / Technical Parameters

参数	Specifications	技术指标/Technique
输出灵敏度	Rated output	1.5 ± 10% mV / V
零点输出	Zero balance	± 2% F.S.
非线性	Non-linearity	0.5% F.S.
滞后	Hysteresis	0.5% F.S.
重复性	Repeatability	0.1% F.S.
蠕变 (30分钟)	Creep (30min)	0.5% F.S.
温度灵敏度漂移	Temp. effect on output	0.05% F.S. / 10°C
零点温度漂移	Temp. effect on zero	0.05% F.S. / 10°C
输入电阻	Input impedance	385 ± 10Ω
输出电阻	Output impedance	350 ± 5Ω
绝缘电阻	Insulation	≥5000MΩ / 50VDC
激励电压	Recommended excitation	10V
最大激励电压	Maximum excitation	15V
温度补偿范围	Compensated temp. range	-10 ~ 60°C
工作温度范围	Operation temp. range	-20 ~ 80 C
安全超载	Safe overload	150% F.S.
极限超载	Ultimate overload	200% F.S.
电缆线尺寸	Cable size	Ø5 × 3000mm
防护等级	Protection class	IP66
连接方式	Cable color code	Input: Red(+) Black(-); Output: Green(+) White(-); 输入: 红 (+) 黑 (-); 输出: 绿 (+) 白 (-);



特点和用途 / Features & Applications

- 不锈钢材料，拉压双向，IP66
- 主要用于试验机、小型焦煤、料位计称，微型拉压力测力设备，如机械手，贴膜机、铆钉机、焊接机、插拔力测试仪
- Made of stainless steel, IP66
- Tension and compression application
- Mainly used for testing machine, miniature tension and pressure test equipment, such as lamination machine, riveting machine, welding machine

受力方式 / Load Direction

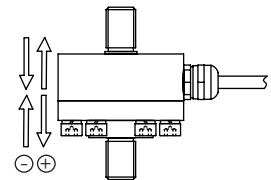

接线图 / Schematic Wiring Diagram

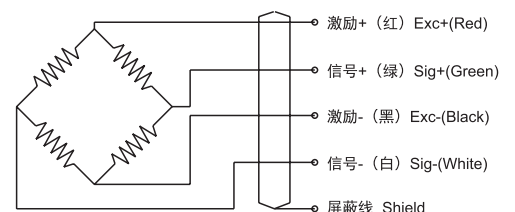

注：屏蔽线不与弹性体相连。

Note: Cable shield is not connected to element.