

尺寸及量程 / Size and Capacity

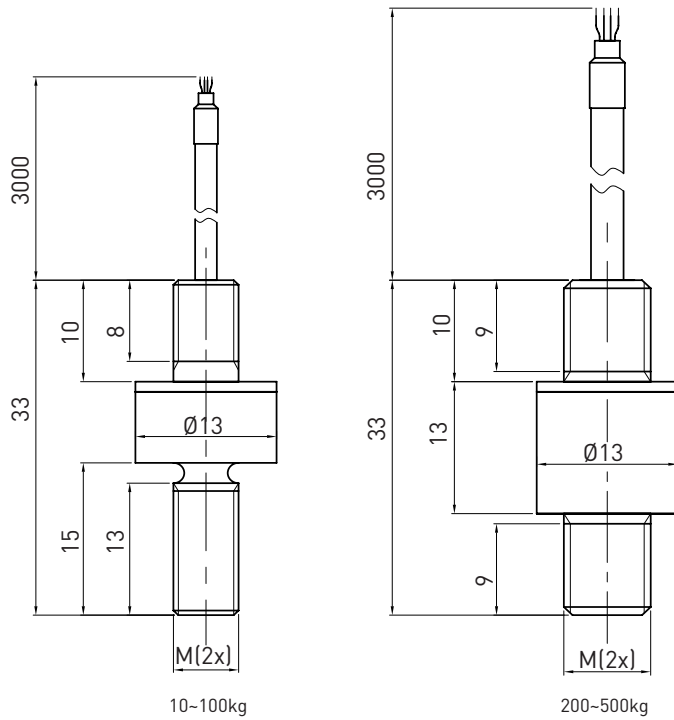

SIZE(mm)	M	电缆线 / Cable	材料 / Material	重量 / Weight
CAP (kg)				
10/15/20/30/50/100	M6	Ø2	不锈钢 / Stainless steel	0.1kg
200/300/400/500	M8	Ø3		



特点和用途 / Features & Applications

- 不锈钢材料
- 微型传感器，高度低
- 拉压双向，IP66
- 用于消费电子测试设备以及其它精度要求不高测力设备
- Made of stainless steel
- Miniature load cell, low profile, ultra compact build size
- Tension and compression application, IP66 protection
- Mainly used for consumer electronics test equipment, low value force measurement and other measuring devices which have undemanding precision requirements

技术参数 / Technical Parameters

参数	Specifications	技术指标/Technique
输出灵敏度	Rated output	1.0 ± 20% mV / V
零点输出	Zero balance	± 5% F.S.
非线性	Non-linearity	1% F.S.
滞后	Hysteresis	0.5% F.S.
重复性	Repeatability	0.5% F.S.
蠕变 (30分钟)	Creep (30min)	0.5% F.S.
输入电阻	Input impedance	350 ± 30 Ω
输出电阻	Output impedance	350 ± 5 Ω
绝缘电阻	Insulation	≥2000M Ω
激励电压	Recommended excitation	5~10V
最大激励电压	Maximum excitation	15V
温度补偿范围	Compensated temp. range	-10 ~ 60°C
工作温度范围	Operation temp. range	-20 ~ 80°C
安全超载	Safe overload	120% F.S.
极限超载	Ultimate overload	200% F.S.
电缆线尺寸	Cable size	3000 mm
防护等级	Protection class	IP66
连接方式	Cable color code	Input: Red(+) Black(-); Output: Green(+) White(-); 输入: 红 (+) 黑 (-); 输出: 绿 (+) 白 (-);

受力方式 / Load Direction

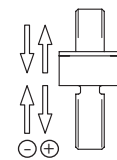

接线图 / Schematic Wiring Diagram

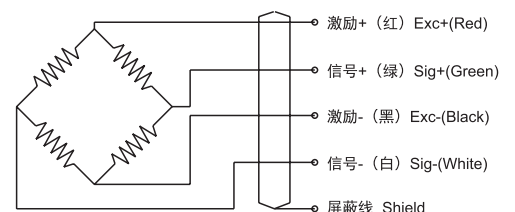

注：屏蔽线不与弹性体相连。

Note: Cable shield is not connected to element.