

LS

CD5

CD4

CD33

CD3

CD22

CD1

UQ1

CD4 series

CD4 Series with linear image sensor and electronic shutter provides accurate measurement.

- Laser displacement sensor features easy setup and operation.
- High accuracy of 0.1 μm resolution and $\pm 0.1\%$ F.S. linearity. (Specular Type)
- Specular type (CD4L-25) optics that are ideal for glass sensing.



SENSORHEAD VARIATION

LS

CD5

CD4

CD33

CD3

CD22

CD1

UQ1

〈For general use〉

Regular
type

CD4-30 (IEC Class 2 「FDA CLASS II」 Type)
CD4-30-3R (High power Class 3R Type)

Short distance

Tire inspection

Measurement range : 30 ±5mm
Resolution : 1 μm
Linearity : ±0.1% F.S.

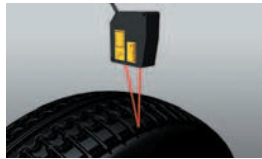
Regular
type

CD4-85 (IEC Class 2 「FDA CLASS II」 Type)
CD4-85-3R (High power Class 3R Type)

Middle distance

Checking clear package of IC mounted on PCB

Measurement range : 85 ±20mm
Resolution : 3 μm
Linearity : ±0.1% F.S.

Regular
type

CD4-350 (IEC Class 2 「FDA CLASS II」 Type)
CD4-350-3R (High power Class 3R Type)

Long distance

Monitoring the die cast

Measurement range : 350 ±100mm
Resolution : 40 μm
Linearity : ±0.1% F.S.



〈For glass material〉

Specular
type

CD4L-25 (IEC Class 1 「FDA CLASS II」 Type)

Specular type

Monitoring warping sagging of glass plate

Measurement range : 25 ±1mm
Resolution : 0.1 μm
Linearity : ±0.1% F.S.

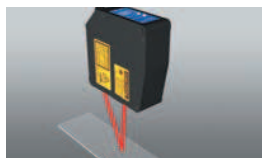

CD4 SENSOR HEADS

CD4 Series laser displacement sensor with linear image sensor and electronic shutter provides accurate measurement.

Measuring range

<General use>

CD4-30
CD4-30-3R Short range : 30 ±5mm

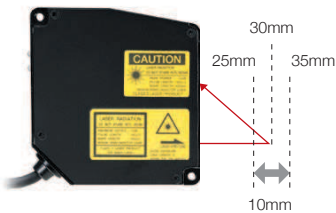

<Glass material>

CD4L-25 Specular type : 25 ±1mm
The optical path is designed to project the correct angle for the detection of specular reflections from transparent objects.

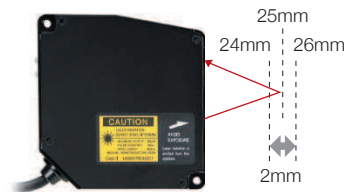

CD4-85
CD4-85-3R Middle range : 85 ±20mm

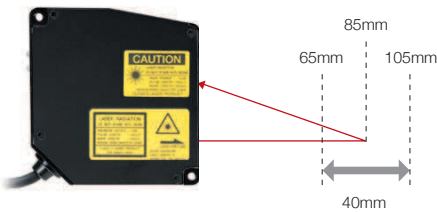

CD4-350
CD4-350-3R Long range : 350 ±100mm

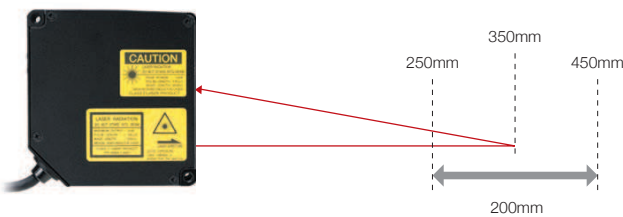

Class 2 (IEC/JIS) CLASS II (FDA) laser product

CD4-30

CD4-85

CD4-350

High power type (models with “-3R”) has class 3 laser



High speed sampling rate

The CD4 Displacement sensor has a 100µsec. sampling rate and high density linear image detector.

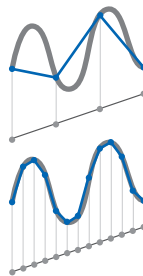

Conventional displacement sensor with slow response.

CD4 Series sensors, high speed sampling rate improves overall accuracy.

Class 3R - High power types

CD4-30-3R

CD4-85-3R

CD4-350-3R

For matte black objects or any application that requires a higher power laser, there are models of the CD4 series available which use a Class 3R light source.



IP67 Environmental rating

The sensing heads of the CD4 series have an IP67 rating for use in applications where they may be exposed to water.



Class 1 (IEC/JIS) CLASS II (FDA) laser product

CD4L-25

CD4L-25 is registered to CDRH. (Center of devices and radiological health)



LS

CD5

CD4

CD33

CD3

CD22

CD1

UQ1

CD4 CONTROLLERS

The CD4 controller is easy to operate with simple pushbutton setup and an LCD display to verify / change the settings.

LCD Display

The CD4A-N(or P) controller has a built-in color display that indicates multiple data values on the same screen.

Distance values from both heads, calculated value, output status, bank number, etc. are displayed on the normal run screen.



Light intensity monitor (For CD4L-25 only)

For stable measurement and improved accuracy the light intensity needs to be adjusted to the optimum setting.

With the built-in monitor the status of the level can be verified.

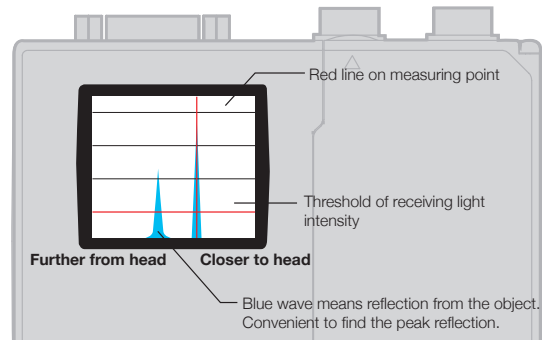

Ten formulas of calculation

| | |
|--------------|---|
| A | Sensor head A |
| B | Sensor head B |
| A+B | Adding of A and B |
| A-B | Gap between A and B |
| -A-B | Reverse of A+B |
| K-A-B | K = distance between sensors. Good for measuring thickness. |
| K+A+B | K = Offset value |
| K+A-B | K = Offset value |
| K+A | Offset the sensor A. K = Offset value |
| K+B | Offset the sensor B. K = Offset value |

8 Banks selections

| Bank No. | Bank 2 input | Bank 1 input | Bank 0 input |
|----------|--------------|--------------|--------------|
| 0 | OFF | OFF | OFF |
| 1 | OFF | OFF | ON |
| 2 | OFF | ON | OFF |
| 3 | OFF | ON | ON |
| 4 | ON | OFF | OFF |
| 5 | ON | OFF | ON |
| 6 | ON | ON | OFF |
| 7 | ON | ON | ON |

Electronic shutter

The microcomputer in the CD4 controller will automatically control the shutter speed depending upon the reflectance of the target.

This will select the best light intensity level for accurate measurement and will help to minimize the error (AUTO Sensitivity Mode).

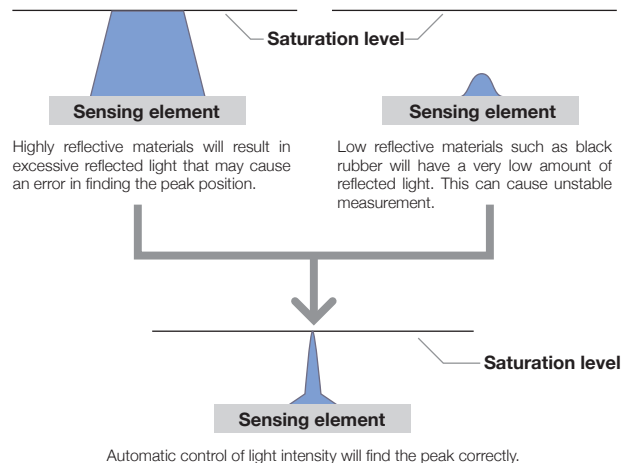

RS-232C Communications

By connecting the CD4 controller to a PC, the following operations can be performed from the PC via RS232C.

- Writing and reading out the setting value
- Reading out the measurement value
- Reading out the control output status
- Operating the control input
- Data buffer function

| | |
|----------------------|-----------------------------|
| Communication method | RS-232C |
| Transmission type | Asynchronous |
| Baud rate | 9600/19200/38400/115200 bps |
| Transmission code | ASCII |
| Data length | 7/8 bit |
| Stop bit length | 1 bit |
| Parity check | Nil/Even number/Odd number |
| Data classification | STX·ETX |

The underlined values are the factory default settings.

Adjust the communication settings of the PC and the CD4 using the values in the above table. The settings of the CD4 controller can be accessed in screen number 14 (RS232C).

Low / High pass filters

High / Low pass filters are built into the CD4 controller. A low pass filter will help to reduce any sudden changes in the measurement while the high pass filter will eliminate slow gradual changes.

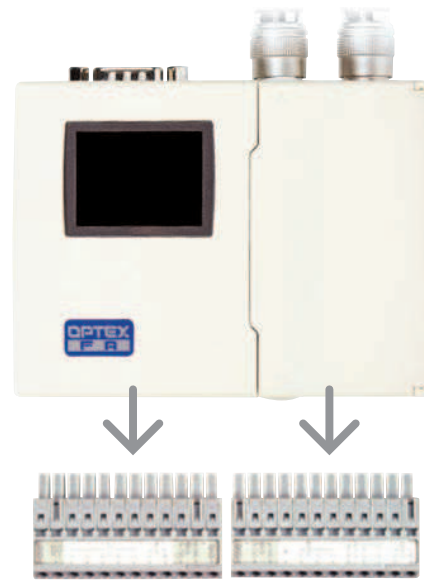

Easy disconnection of QD type.

5 Independent outputs are available

This is convenient for sorting items according to size. Each of the 5 comparator outputs can be set independently, all outputs have a high and low threshold limit.

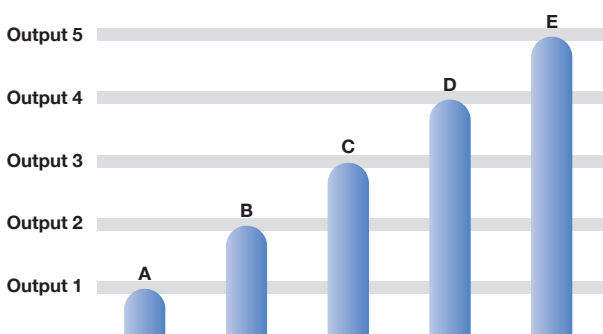

Two sensing heads can be controlled

Therefore it computes for the purpose of measuring thickness, width, etc.

Independent measurement from each head is possible as well. Any combination of measurement heads (30, 85, 350) can be used together.

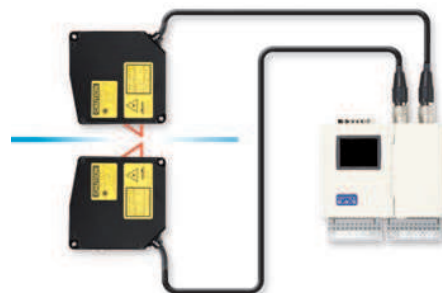

LS

CD5

CD4

CD33

CD3

CD22

CD1

UQ1

Dimensions

CD4 series sensor head

Model No. : CD4-30/-30-3R/-85/-85-3R

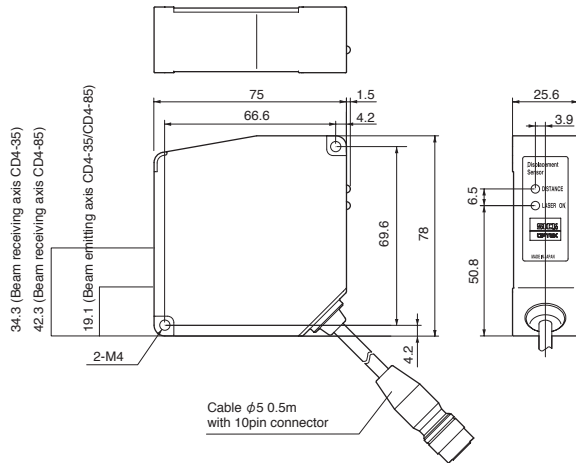

Model No. : CD4-350/-350-3R

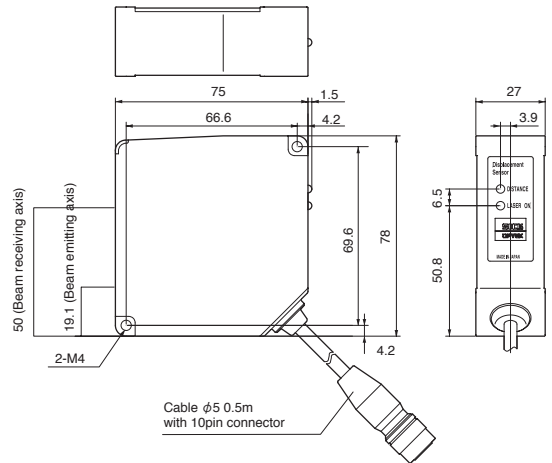

CD4L-25 Sensor head

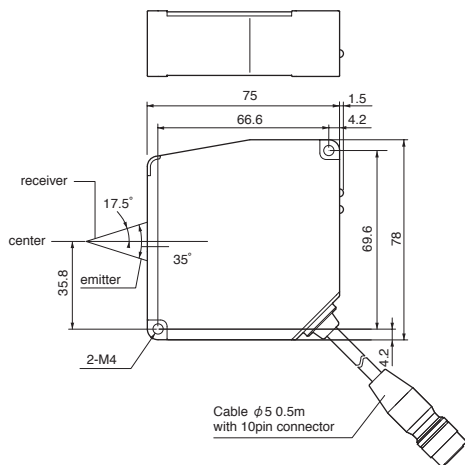

Cable

Model No. : CD4CN-S-ROBOT

: Extension 2m cable to connect the sensor head

Model No. : CD4CN-5S-ROBOT

: Extension 5m cable to connect the sensor head



Controller

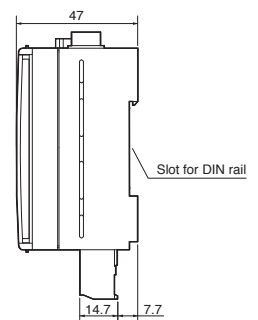
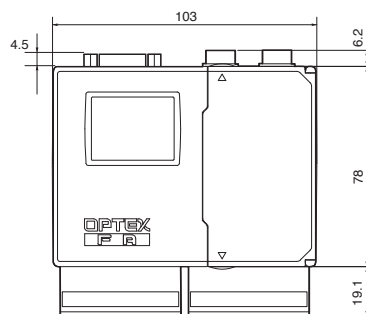
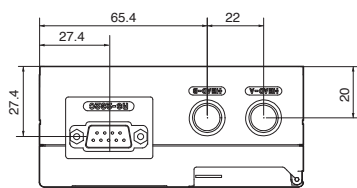

(mm)

Specifications

CD4 series

| Model | IEC Class 1 (FDA CLASS II) Type | CD4-30 | CD4-85 | CD4-350 |
|----------------------------------|---------------------------------|--|-----------|------------|
| | High power Class 3R Type | CD4-30-3R | CD4-85-3R | CD4-350-3R |
| Measurement range | | 30 ±5mm | 85 ±20mm | 350 ±100mm |
| Light source | (Regular type) | Class 2 (IEC / JIS) CLASS II (FDA) Red laser diode, 650nm, max 1m W | | |
| | (High power type) | Class 3R (IEC / JIS) CLASS III a (FDA) Red laser diode, 650nm, max 5mW | | |
| Spot size (*1) | | 30×100μm | 70×290μm | 300×700μm |
| Linearity (*2) | | ±0.1% F.S. | | |
| Resolution (*3) | | 1μm | 3μm | 40μm |
| Supply voltage | | Supplied by CD4A-N / P controller | | |
| Temp drift | | ±0.01% F.S. / °C | | |
| Laser emission indicator | | Green = Laser emission | | |
| Measurement indicator | | Red = In range, closer than center 5% of measurement range (0 to 45%) | | |
| | | Orange = Within ±5% of the center of the measuring range | | |
| | | Green = In range, farther than center 5% of measurement range (55 to 100%) | | |
| | | Red / Green alternating = Out of measuring range | | |
| Protection category | | IP67 | | |
| Ambient temp / humidity | | -10 to +45 °C (14 to 113 °F), 35 to 85% RH | | |
| Storage temp / humidity | | -20 to +60 °C (-4 to 140 °F), 35 to 85% RH | | |
| Environmental illuminance | | Incandescent lamp = Max 3,000 lux | | |
| Vibration resistance | | 10 to 55 Hz double amplitude 1.5mm for XYZ | | |
| Shock resistance | | 50G (500m/s ²) | | |
| Cable | | 50cm (19.7 inch) cable | | |
| Cable extension | | CD4CN-S-ROBOT (2m, 78 inch), CD4CN-5S-ROBOT (5m, 197 inch) | | |
| Material | | Aluminum diecast | | |

*1 Defined with center strength 1/e² (13.5%). There may be leak light other than the spot size. The sensor may be affected when there is a highly reflective object close to the detection area.

*2 256 times in average (using the special amplifier), object: White ceramic. The value is subject to objects.

*3 The typical value in the conditions of 256 times in average (using the special amplifier), object: White ceramic, distance range: Middle. The value is subject to objects.

CD4L-25

| Model | CD4L-25 |
|----------------------------------|--|
| Measurement range | 25 ±1mm |
| Light source | Class 1 (IEC / JIS) CLASS II (FDA) Laser, 650nm, max 390 μW |
| Spot size (*1) | 25×35 μm |
| Linearity (*2) | ± 0.1% F.S. |
| Resolution (*3) | 0.1 μm |
| Supply voltage | Supplied by CD4A-LN/LP controller |
| Temp drift | ±0.01% F.S. / °C |
| Laser emission indicator | Green = Laser emission |
| Measurement indicator | Red = In range, closer than center 5% of measurement range (0 to 45%) |
| | Orange = Within ±5% of the center of the measuring range |
| | Green = In range, farther than center 5% of measurement range (55 to 100%) |
| | Red / Green alternating = Out of measuring range |
| Protection category | IP67 |
| Ambient temp / humidity | -10 to +45 °C (14 to 113 °F), 35 to 85% RH |
| Storage temp / humidity | -20 to +60 °C (-4 to 140 °F), 35 to 85% RH |
| Environmental illuminance | Incandescent lamp = Max 3,000 lux |
| Vibration resistance | 10 to 55 Hz double amplitude 1.5mm for XYZ |
| Shock resistance | 50G (500m/s ²) |
| Cable | 50cm (19.7 inch) cable |
| Cable extension | CD4CN-S-ROBOT (2m, 78 inch), CD4CN-5S-ROBOT (5m, 197 inch) |
| Material | Aluminum diecast |

*1 Defined with center strength 1/e² (13.5%). There may be leak light other than the spot size. The sensor may be affected when there is a highly reflective object close to the detection area.

*2 256 times in average (using the special amplifier), object: evaporated aluminum mirror. The value is subject to objects.

*3 The typical value in the conditions of 256 times in average (using the special amplifier), object: White ceramic, distance range: Middle. The value is subject to objects.

LS

CD5

CD4

Controller

CD33

CD3

CD22

CD1

UQ1

| Model | | CD4A-N / -LN (NPN output type) | CD4A-P / -LP (PNP output type) |
|--------------------------------|---------------------------------|--|---------------------------------|
| Number of heads | | Max.2 pcs | |
| Sampling period | | 100 μ s | |
| Supply voltage | | 12 - 24VDC \pm 10% | |
| Power consumption | | 270mA / 24VDC (When connected with 2 sensor heads. Including analog current output) | |
| Temp drift | | \pm 0.01% F.S. / $^{\circ}$ C | |
| Analog output | ANG (V) [A] [B] | Voltage output \pm 5V / F.S. (Output impedance 100 Ω , resolution 1mV) | |
| | ANG (mA) [A] [B] | Current output 4 to 20mA / F.S. (Load impedance 300 Ω , resolution 1.5 μ A) | |
| Alarm output | ALM A,ALM B | NPN open collector | PNP open collector |
| | | Max. 100mA / 24VDC (residual voltage Max. 1.8V) Turns ON when the sensor head fails in measurement. | |
| Control output | JDGE 1 to 5 | NPN open collector | PNP open collector |
| | | Max. 100mA / 24VDC (residual voltage Max. 1.8V) HI / LO setting and Hysteresis setting are available for each output. | |
| Bank input | BANK 0 to 2 | ON when connected to GND | ON when connected to 12 - 24VDC |
| | | 8 banks selectable | |
| Hold input | HOLD A, HOLD B, HOLD RST | ON when connected to GND | ON when connected to 12 - 24VDC |
| | | Laser off or measurement value holding (selectable in the menu) | |
| Zero reset input | ZERO A, ZERO B | ON when connected to GND | ON when connected to 12 - 24VDC |
| | | Zero reset of head A measurement value / Head B measurement value / Calculation value is available. | |
| Optional features | | Average sampling times, Filter mode (Cut-off frequency) , Calculation, Hold setting, Output during alarm, Output control (Hysteresis) , Analog output, Sensor head sensitivity control, Timer function, Memory function, Memory bank function, Auto zero reset | |
| Display type | | LCD display | |
| Protection category | | IP20 | |
| Ambient temp / humidity | | -10 to +45 $^{\circ}$ C (Non-condensing) / 35 to 85% RH | |
| Storage temp / humidity | | -20 to +60 $^{\circ}$ C / 35 to 85% RH | |
| Vibration resistance | | 10 to 55Hz, Double amplitude 1.5mm, 2h for XYZ axis | |
| Shock resistance | | 20G (196m/s ²) | |
| Material | | Chassis: Polycarbonate, Connection terminals: Nylon 66 | |
| Weight | | 240g (including connection terminals) | |

Linearity (Typical example data)

CD4 series : by material

Model No. : CD4-30 / CD4-30-3R

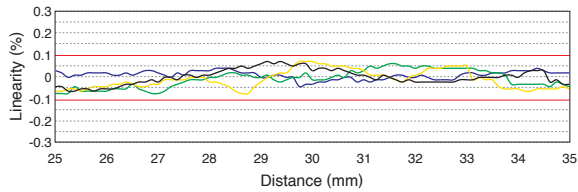

Model No. : CD4-85 / CD4-85-3R

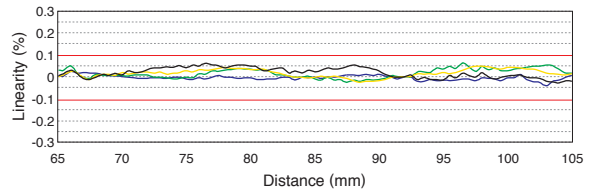

Model No. : CD4-350 / CD4-350-3R

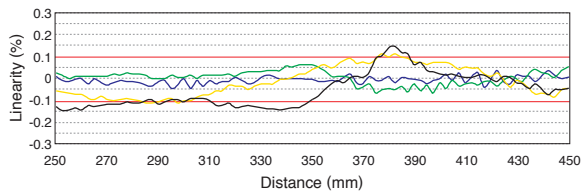

- White ceramic
- Aluminum
- Gray ceramic
- Black rubber

CD4L-25 : by angle

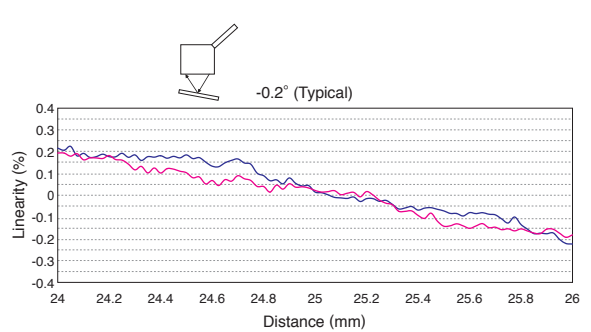
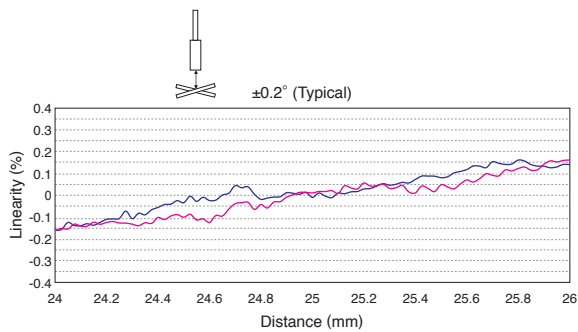
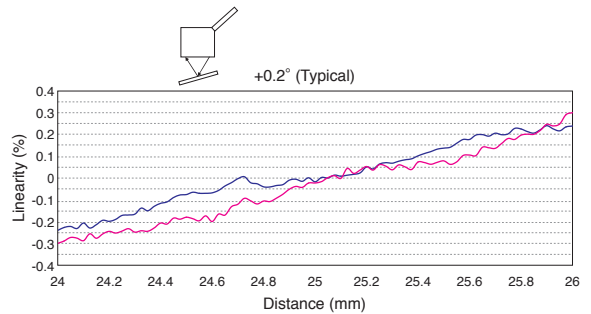
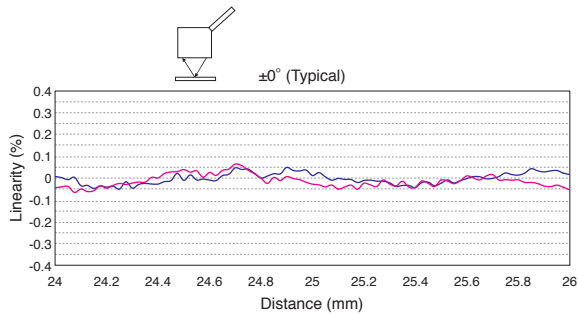

- Mirror(SENS=MIN)
- Glass(SENS=8)

LS

CD5

CD4

CD33

CD3

CD22

CD1

UQ1

Spot size

CD4 series

Model No. : CD4-30 / CD4-30-3R

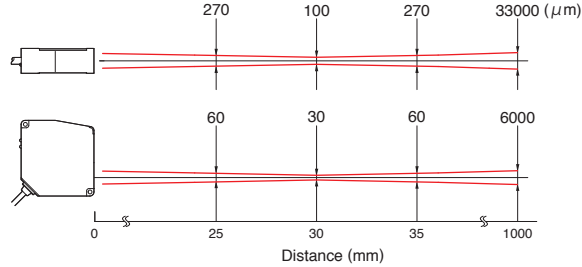

Model No. : CD4-85 / CD4-85-3R

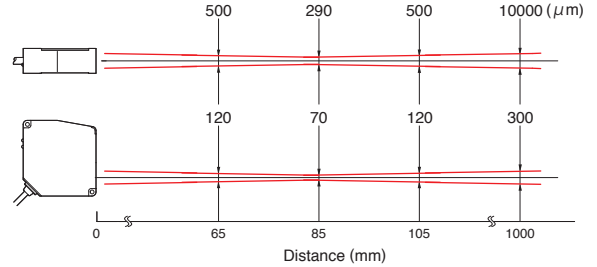

Model No. : CD4-350 / CD4-350-3R

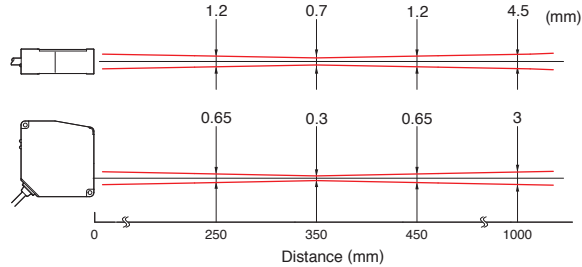

CD4L-25

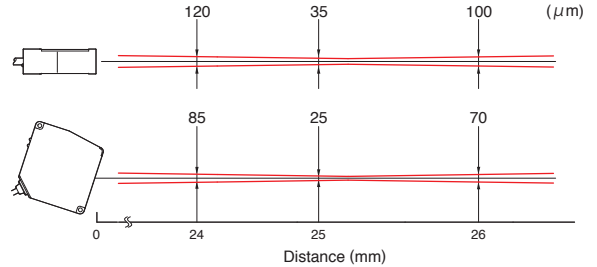

Interference area

CD4 series

Model No. : CD4-30/CD4-30-3R

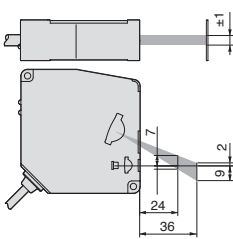

Model No. : CD4-85/CD4-85-3R

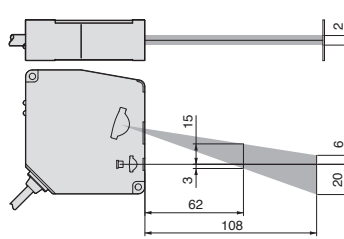

Model No. : CD4-350/CD4-350-3R

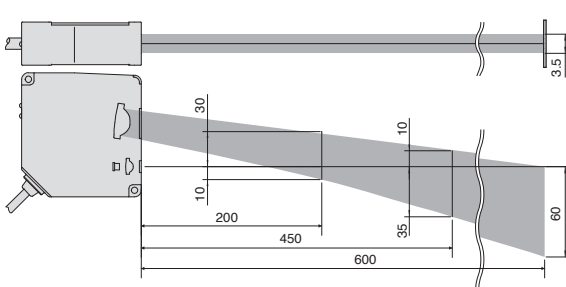

CD4L-25

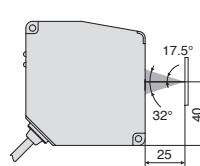

(mm)



Input / Output diagrams

LS

CD5

CD4

CD33

CD3

CD22

CD1

UQ1

NPN model bank input
Hold input
Zero reset input

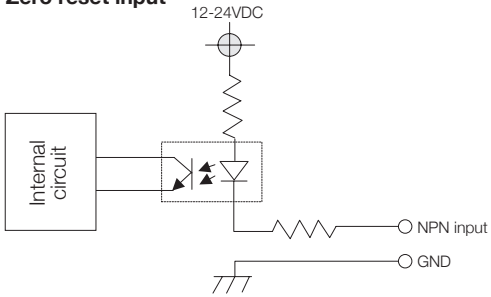

NPN model control output
Alarm output

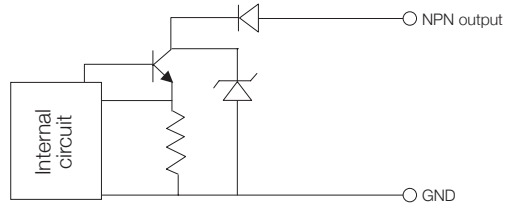

PNP model bank input
Hold input
Zero reset input

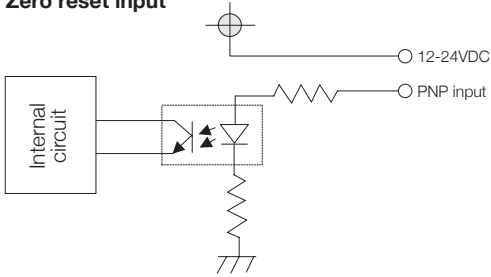

NPN model control output
Alarm output

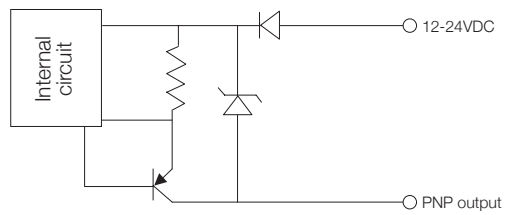

Analog output (A/B)

