

Data Sheet - Series 6 Miniature Position Transducers With FlexSignal™ Integrated Signal Conditioning

Key Features

1. 85-Inch (2159-mm) Maximum Travel (Model 62)
2. Choice of FlexSignal™ Analog and Digital Output Signals (Factory Set)
 - o [Voltage Divider](#)
 - o [Low-Level Bridge](#) (B Circuit / Strain Gage Compatible)
 - o [Voltage Conditioner](#)
 - Flexible, User-Adjustable Zero and Span Controls
 - 0-5 VDC, 0-10 VDC, ±5 VDC, ±10 VDC, and [more](#)
 - o [4-20 mA](#) (Current Loop)
 - o [Quadrature](#) (Standard- and High-Resolution Digital)
3. AccuTrak™ Threaded Drum For Enhanced Repeatability
4. DirectConnect™ Sensor-To-Drum Technology = Zero Backlash, No Torsion Springs or Clutches
5. NEMA 4 / IP 66 Environmental Protection
6. Flexible Mounting Bases
7. Industrial Operating Temperature Ranges
8. Choice of Electrical Terminations: MIL-C-5015, DIN 45326, Lemo, flying leads

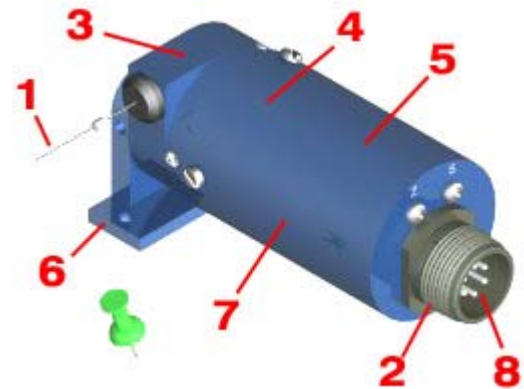

Electrical Outputs - Voltage Divider

| VOLTAGE DIVIDER (hybrid or conductive plastic precision potentiometer) | | |
|--|---|--|
| Item | 1-turn sensor | 3-, 5-, and 10-turn sensors |
| Resistance: Value, Tolerance | 5K ohms, ±10% | 5K ohms, ±10% |
| Travel: Electrical | 340° | 1080° (3-turn), 1800° (5-turn), 3600° (10-turn) |
| Travel: Mechanical | 360° continuous | 1080° (3-turn), 1800° (5-turn), 3600° (10-turn) (+15° -0°) |
| Mechanical Life | 5 million shaft revolutions min | 5 million shaft revolutions min |
| Power Rating | 1.0 W at 158° F (70° C); 50 VDC / 12 mA max | 2.0 W at 158° F (70° C); 50 VDC / 12 mA max |
| Independent Linearity Error | ±1.0% max per VRCI-P-100A | ±0.25% max per VRCI-P-100A |
| Output Smoothness | 0.1% max | 0.051% max |

[Firstmark Controls](#)

An ISO9001:2000/AS9100B-Compliant Company
 1176 Telecom Drive • Creedmoor, NC 27522 USA
 1-866-912-6232 • Fax: 919-682-3786 •
info@Firstmarkcontrols.com

CO#37219, 8/12/08, Rev.A
 Business hours: Mon-Fri, 8:00am to 5:00pm (Eastern time)
 All specifications subject to change without notice.
 © 1996-2007 Firstmark Controls All rights reserved.



Data Sheet - Series 6 Miniature Position Transducers With FlexSignal™ Integrated Signal Conditioning

| | | |
|-----------------------|---------------------------------------|--|
| Insulation Resistance | 1000 Mohms min at 750 Vrms | 1000 Mohms min at 750 Vrms |
| Dielectric Strength | 750 Vrms min | 1000 Vrms min |
| Resolution | infinite signal | infinite signal |
| Operating Temperature | -40° to 185° F (-40° to 85° C) | -40° to 185° F (-40° to 85° C) |
| Shock / Vibration | 100 g for 6 ms / 10 to 500 Hz at 10 g | 100 g for 6 ms / 10 to 2000 Hz at 15 g |
| Thermal Coefficient | ±0.01%/°C max | ±0.01%/°C max |

The potentiometer type of a specific potentiometer-based position transducer partnumber is designated by the 5th position of the part number counting left to right. Example: 60-11-5222 contains a 1-turn potentiometer while 60-60-8633 contains a 10-turn potentiometer ("0" indicates a 10-turn potentiometer).

| Electrical Connection | | | | |
|-----------------------|---------------------|---------------------|---------------------|---|
| <u>Code 1 (wire)</u> | <u>Code 2 (pin)</u> | <u>Code 3 (pin)</u> | <u>Code 4 (pin)</u> | <u>Signal</u> |
| red | A | 1 | 1 | input, V+ ground, common, V-, S- output, signal, S+ |
| black | B | 2 | 2 | |
| white | C | 3 | 3 | |

Electrical Outputs - Low-Level Bridge

| LOW-LEVEL BRIDGE (B Circuit / Strain Gage Compatible) | |
|---|--|
| Item | Value |
| Supply Voltage | 7 to 40 VDC max |
| Supply Current | 20 mA max |
| Reverse Polarity Protection | yes |
| Increasing/Decreasing Output Options | yes |
| Output Signal | 0.2 mV/V to 3.75 mV/V at 24 VDC supply voltage |
| Zero Adjust | 0% to 100% of range (adjustable output via 2 x trim potentiometers) |
| Span Adjust | see <i>Typical Outputs</i> table below (adjustable output via 2 x trim potentiometers) |
| Independent Linearity Error | see Voltage Divider specification above |
| Insulation Resistance | 1000 Mohms min |
| Resolution | infinite signal |
| Operating Temperature | -40° to 185° F (-40° to 85° C) |

[Firstmark Controls](#)
An ISO9001:2000/AS9100B-Compliant Company
1176 Telecom Drive • Creedmoor, NC 27522 USA
1-866-912-6232 • Fax: 919-682-3786 •
info@Firstmarkcontrols.com

CO#37219, 8/12/08, Rev.A
Business hours: Mon-Fri, 8:00am to 5:00pm (Eastern time)
All specifications subject to change without notice.
© 1996-2007 Firstmark Controls All rights reserved.



Data Sheet - Series 6 Miniature Position Transducers With FlexSignal™ Integrated Signal Conditioning

| | |
|---------------------|---------------|
| Thermal Coefficient | ±0.01%/°C max |
|---------------------|---------------|

| Typical Outputs | | | |
|----------------------|---------------|---------------|--------------------------|
| Supply Voltage (VDC) | Min Span (mV) | Max Span (mV) | Sensitivity Range (mV/V) |
| 7 | 4.92 | 20.5 | 0.7 to 2.928 |
| 12 | 4.92 | 41 | 0.41 to 3.42 |
| 24 | 4.92 | 90 | 0.205 to 3.75 |

| Electrical Connection | | | | |
|-----------------------|---------------------|---------------------|---------------------|------------|
| <u>Code 1 (wire)</u> | <u>Code 2 (pin)</u> | <u>Code 3 (pin)</u> | <u>Code 4 (pin)</u> | Signal |
| red | A | 1 | 1 | V+ |
| black | B | 2 | 2 | V- |
| white | C | 3 | 3 | S+ |
| green | D | 4 | 4 | S-, ground |

To change the output signal's range, follow these steps:

1. Remove the 2X sealing screws labeled Z and S to reveal the zero and span trim potentiometers.
2. Extend the displacement cable to the desired start location and adjust the zero trim potentiometer until you get the desired electrical output.
3. Extend the displacement cable to the desired finish location and adjust the span trim potentiometer until you get the desired electrical output.
4. Repeat steps 2 and 3.
5. Replace the 2X sealing screws.

Electrical Outputs - Voltage Conditioner

| VOLTAGE CONDITIONER (unregulated input) | | |
|---|--|---|
| Item | Unipolar (0-5 VDC, 0-10 VDC, Etc.) | Bipolar (±5 VDC, ±10 VDC, Etc.) |
| Supply Voltage | 7 to 40 VDC for 0-5 VDC 12 to 40 VDC for 0-10 VDC | 12 to 40 VDC for ±5 VDC 22 to 40 VDC for ±10 VDC |
| Supply Current | 20 mA max | 20 mA max |
| Reverse Polarity Protection | yes | yes |
| Increasing/Decreasing Output Options | yes | yes |
| Output Signal (User Adjustable) | 0-5 VDC, 0-10 VDC, 5-0 VDC, 10-0 VDC, and user-adjustable values (adjustable output via 2 x trim potentiometers) | ±5 VDC, ±10 VDC, and user-adjustable values (adjustable output via 2 x trim potentiometers) |



Data Sheet - Series 6 Miniature Position Transducers

With FlexSignal™ Integrated Signal Conditioning

| | | |
|-----------------------------|--|--|
| Zero Adjust | 0% to 100% of range | 0% to 100% of range |
| Span Adjust | 20% to 65% at 7 VDC supply 5% to 95% at 40 VDC supply | 20% to 65% at 7 VDC supply 5% to 95% at 40 VDC supply |
| Independent Linearity Error | see Voltage Divider specification above | see Voltage Divider specification above |
| Insulation Resistance | 1000 Mohms min | 1000 Mohms min |
| Resolution | infinite signal | infinite signal |
| Operating Temperature | -40° to 185° F (-40° to 85° C) | -40° to 185° F (-40° to 85° C) |
| Thermal Coefficient | ±0.01%/°C max | ±0.01%/°C max |

| Electrical Connection | | | | |
|-------------------------------|------------------------------|------------------------------|------------------------------|------------|
| Code 1 (wire) | Code 2 (pin) | Code 3 (pin) | Code 4 (pin) | Signal |
| red | A | 1 | 1 | V+ |
| black | B | 2 | 2 | V- |
| white | C | 3 | 3 | S+ |
| green | D | 4 | 4 | S-, ground |

To change the output signal's range, follow these steps:

1. Remove the 2X sealing screws labeled Z and S to reveal the zero and span trim potentiometers.
2. Extend the displacement cable to the desired start location and adjust the zero trim potentiometer until you get the desired electrical output.
3. Extend the displacement cable to the desired finish location and adjust the span trim potentiometer until you get the desired electrical output.
4. Repeat steps 2 and 3.
5. Replace the 2X sealing screws.

Electrical Outputs - 4-20 mA

| 4-20 mA (2-wire current transmitter) | |
|--------------------------------------|---|
| Item | Value |
| Supply Voltage | 12 to 40 VDC with reverse polarity protection |
| Supply Current | 35 mA max |
| Output Signal | 4-20 mA (user adjustable) with increasing and decreasing output options |
| Zero Adjust | 0 to 5% of range (adjustable output via 2 x trim potentiometers) |
| Span Adjust | 50 to 100% of range (adjustable output via 2 x trim potentiometers) |
| Independent Linearity Error | see Voltage Divider specification above |

[Firstmark Controls](#)

An ISO9001:2000/AS9100B-Compliant Company
 1176 Telecom Drive • Creedmoor, NC 27522 USA
 1-866-912-6232 • Fax: 919-682-3786 •
info@Firstmarkcontrols.com

CO#37219, 8/12/08, Rev.A
 Business hours: Mon-Fri, 8:00am to 5:00pm (Eastern time)
 All specifications subject to change without notice.
 © 1996-2007 Firstmark Controls All rights reserved.

Data Sheet - Series 6 Miniature Position Transducers
With FlexSignal™ Integrated Signal Conditioning

| | |
|-----------------------|--------------------------------|
| Insulation Resistance | 1000 Mohms min at 750 Vrms |
| Resolution | infinite signal |
| Operating Temperature | -40° to 185° F (-40° to 85° C) |
| Thermal Coefficient | ±0.01%/°C max |

A Note on Load Resistance in 4-20 mA Current Loops - The maximum load resistance or loop resistance is the maximum resistance of all the loads that are connected in series with the circuit. This includes all instrumentation equipment such as power supply and multimeter. The maximum load resistance (RLmax) depends on 2 factors: the voltage supply (Vps) and the maximum loop current (Iloop). For the Series 6 4-20 mA circuit, $RL_{max} = (V_{ps} - 11.6) / I_{loop}$

Example:

Vps = 24 V
 Iloop = 30 mA
 $RL_{max} = (24 - 11.6) / 30 = 0.413 \text{ Kohms}$

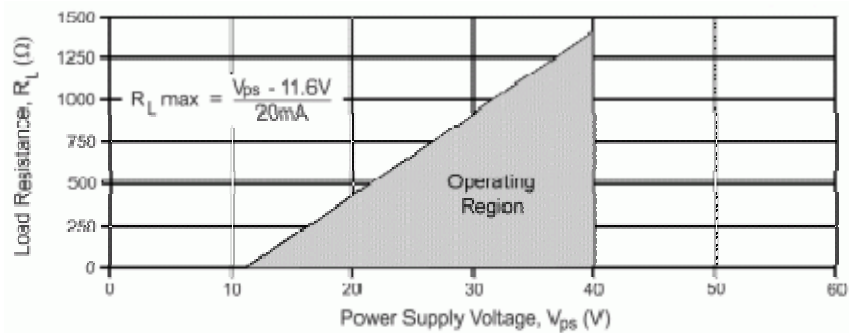

| Electrical Connection | | | | |
|-----------------------|---------------------|---------------------|---------------------|--------|
| <u>Code 1 (wire)</u> | <u>Code 2 (pin)</u> | <u>Code 3 (pin)</u> | <u>Code 4 (pin)</u> | Signal |
| red | A | 1 | 1 | V+ |
| black | B | 2 | 2 | V- |

To change the output signal's range, follow these steps:

1. Remove the 2X sealing screws labeled Z and S to reveal the zero and span trim potentiometers.
2. Extend the displacement cable to the desired start location and adjust the zero trim potentiometer until you get the desired electrical output.
3. Extend the displacement cable to the desired finish location and adjust the span trim potentiometer until you get the desired electrical output.
4. Repeat steps 2 and 3.



Data Sheet - Series 6 Miniature Position Transducers
With FlexSignal™ Integrated Signal Conditioning

5. Replace the 2X sealing screws.

Electrical Outputs - Digital

| DIGITAL (incremental optical encoder (quadrature)) | | |
|--|--|---|
| <i>Item</i> | <i>Standard Resolution</i> | <i>High Resolution</i> |
| Power Requirement | 5 ±0.50 VDC | 5 to 26 VDC |
| Supply Current | 29 mA max at 5 VDC | 35 mA max at 5 VDC |
| Logic Output | open collector and 3.3 Kohm pull-up resistor (TTL) | open collector with Schmitt trigger and 10 Kohm pull-up resistor (push-pull differential line driver) |
| Power Consumption | 145 mW max, 3.86 mA sink current at 0.40 VDC | 150 mW max, 16 mA sink current at 0.40 VDC |
| Travel: Electrical, Mechanical | 360° continuous | 360° continuous |
| Mechanical Life | 100 million shaft revolutions min | 100 million shaft revolutions min |
| Resolution | 1200 quadrature pulses per revolution | 8192 quadrature pulses per revolution |
| Output | 2-bit (quadrature) code, A leads B by 90° w/CW | 2-bit (quadrature) code, A leads B by 90° w/CW |
| Operating Temperature | 14° to 185° F (-10° to 85° C) | -4° to 212° F (-20° to 100° C) |
| Shock / Vibration | 100 g for 6 ms / 5 to 2000 Hz, 20 g | 50 g for 11 ms / 50 to 500 Hz at 20 g |

| Electrical Connection | | | | | | |
|-----------------------|----------------------------|-----------------------------|----------------------------|----------------------------|----------------------------|---------------|
| <i>Resolution</i> | <i>Pin/Wire Assignment</i> | | | | | |
| | <i>Sensor Pin</i> | <u><i>Code 1 (wire)</i></u> | <u><i>Code 2 (pin)</i></u> | <u><i>Code 3 (pin)</i></u> | <u><i>Code 4 (pin)</i></u> | <i>Signal</i> |
| Standard | - | orange | A | 1 | 1 | +5 VDC |
| | - | white/orange | B | 2 | 2 | ground |
| | - | blue | C | 3 | 3 | channel A |
| | - | white/blue | D | 4 | 4 | channel B |
| High | 1 | red | A | 1 | 1 | Signal common |
| | 2 | gray | B | 2 | 2 | +VDC |
| | 3 | brown | C | - | 3 | Z |
| | 4 | green | - | - | - | Z' |
| | 5 | blue | D | 4 | 4 | B |
| | 6 | orange | - | - | - | B' |

[Firstmark Controls](http://www.FirstmarkControls.com)
 An ISO9001:2000/AS9100B-Compliant Company
 1176 Telecom Drive • Creedmoor, NC 27522 USA
 1-866-912-6232 • Fax: 919-682-3786 •
info@Firstmarkcontrols.com

CO#37219, 8/12/08, Rev.A
 Business hours: Mon-Fri, 8:00am to 5:00pm (Eastern time)
 All specifications subject to change without notice.
 © 1996-2007 Firstmark Controls All rights reserved.



Data Sheet - Series 6 Miniature Position Transducers
With FlexSignal™ Integrated Signal Conditioning

| | | | | | | |
|--|----|--------|---|---|---|------|
| | 7 | yellow | E | 3 | 5 | A |
| | 8 | white | - | - | - | A' |
| | 9 | purple | - | - | - | N/C |
| | 10 | black | F | - | 6 | case |

| Nominal Resolution by Model Number (Digital) | | | | | | |
|--|--------|------|----------------------|-----------|------------------|-----------|
| Model | inches | mm | Standard Resolution# | | High Resolution# | |
| | | | pulses/in | pulses/mm | pulses/in | pulses/mm |
| 60-35 | 21.25 | 540 | 278 | 11 | 1895 | 75 |
| 61-45 | 30.00 | 762 | 197 | 8 | 1344 | 53 |
| 62-55 | 42.50 | 1080 | 140 | 6 | 954 | 37.6 |
| 62-60 | 85.00 | 2159 | 140 | 6 | 954 | 37.6 |

after quadrature decode by user

Other Specifications

| | |
|-----------------------------|---|
| Case/Drum Materials | precision-machined, anodized 2024 aluminum |
| Displacement Cable | 0.018-inch (0.46-mm) dia., 7-by-7 stranded stainless steel, 40-lb (177-N) min breaking strength |
| Displacement Cable Hardware | 1 each of 300196 loop sleeve , 300292 copper sleeve , 300688 ball-end plug , 300495 pull ring , 160026 brass swivel , and 301003 nickel swivel ; all items provided uncrimped |
| Nominal Mass | Model 60: 6 oz (170 g), Model 61: 8 oz (227 g), Model 62: 11 oz (312 g) |
| Environmental Sealing | NEMA 4 / IP 66 |

Model Numbers and Cable Tension

[Firstmark Controls](#)
 An ISO9001:2000/AS9100B-Compliant Company
 1176 Telecom Drive • Creedmoor, NC 27522 USA
 1-866-912-6232 • Fax: 919-682-3786 •
info@Firstmarkcontrols.com

CO#37219, 8/12/08, Rev.A
 Business hours: Mon-Fri, 8:00am to 5:00pm (Eastern time)
 All specifications subject to change without notice.
 © 1996-2007 Firstmark Controls All rights reserved.



Data Sheet - Series 6 Miniature Position Transducers
With FlexSignal™ Integrated Signal Conditioning

| Model | Range | | Nominal Displacement Cable Tension Range (Full Retraction to Full Extraction) | | | | | | | |
|-------|--------|------|---|---------------|----------------|---------------|----------------|---------------|-----------|---------|
| | inches | mm | Opt 5 | | Opt 6 | | Opt 7 | | Opt 8 | |
| | | | oz. | N | oz. | N | oz. | N | oz. | N |
| 60-11 | 4.00 | 102 | 4 to 8 | 1 to 2 | 5 to 12 | 1 to 4 | 12 to 20 | 3 to 6 | 28 to 55 | 7 to 16 |
| 60-25 | 13.50 | 343 | 7 to 20 | 2 to 6 | 12 to 28 | 3 to 8 | 18 to 53 | 5 to 15 | 30 to 134 | 8 to 37 |
| 60-35 | 21.25 | 540 | 5 to 12 | 1 to 3 | 7 to 19 | 2 to 5 | 12 to 33 | 3 to 9 | 14 to 79 | 4 to 22 |
| 61-45 | 30.00 | 762 | - | - | 5 to 12 | 1 to 3 | 8 to 23 | 2 to 6 | 9 to 60 | 3 to 17 |
| 62-55 | 42.50 | 1080 | - | - | 4 to 14 | 1 to 4 | 7 to 17 | 2 to 5 | 8 to 41 | 2 to 11 |
| 62-60 | 85.00 | 2159 | - | - | - | - | - | - | 15 to 45 | 4 to 13 |

Bolded entries are standard cable tension.

Displacement Cable Maximum Acceleration by Model Number

| Model | Max Cable Acceleration (g's) | | | |
|-------|------------------------------|--------|--------|--------|
| | Opt. 5 | Opt. 6 | Opt. 7 | Opt. 8 |
| 60-11 | 8 | 10 | 23 | 69 |
| 60-25 | 55 | 65 | 109 | 165 |
| 60-35 | 30 | 40 | 75 | 70 |
| 61-45 | - | 56 | 72 | 95 |
| 62-55 | - | 18 | 31 | 45 |
| 62-60 | - | - | - | 15 |



Data Sheet - Series 6 Miniature Position Transducers With FlexSignal™ Integrated Signal Conditioning

Ordering Codes

| Order Code Format | Description |
|---|---------------------|
| ab-cd-efgh | position transducer |
| Example: 60-11-62B1 (Model 60-11 (Series 60, 4-in (102-mm) range), cable tension: Opt. 6, bridge circuit, base: big foot (60/61), and flying leads) | |

| Variable | Value | Description |
|----------|-------------|--|
| ab-cd | __-__-__-__ | size and range (model number) |
| e | 5 | cable tension: Opt. 5 |
| | 6 | cable tension: Opt. 6 |
| | 7 | cable tension: Opt. 7 |
| | 8 | cable tension: Opt. 8 |
| f | 1 | voltage divider |
| | 2 | bridge circuit - factory preset to 0-10 mV (increasing output), adjustable output via 2 x trim potentiometers |
| | 3 | bridge circuit - factory preset to 10-0 mV (decreasing output), adjustable output via 2 x trim potentiometers |
| | 4 | voltage conditioner - factory preset to 0-5 VDC (increasing output), adjustable output via 2 x trim potentiometers |
| | 5 | voltage conditioner - factory preset to 5-0 VDC (decreasing output), adjustable output via 2 x trim potentiometers |
| | 6 | 4-20 mA (increasing output), adjustable output via 2 x trim potentiometers |
| | 7 | 20-4 mA (decreasing output), adjustable output via 2 x trim potentiometers |
| | 8 | digital (standard resolution, quadrature) |
| | 9 | digital (high resolution, quadrature) |
| g | 0 | base: None |
| | 1 | base: Mounting Disk; pn 160040-1 (cannot be ordered with a RoundAbout™ cable guide) |
| | 2 | base: Standard (60); pn 160015-1 |
| | 3 | base: Standard (61); pn 160015-3 |
| | 4 | base: Standard (62); pn 160015-5 |
| | B | base: Big Foot; (60/61) pn 160015-[13] (62) pn 160015-[15] |
| | C | base: Standard (60) with RoundAbout™ cable guide |
| | D | base: Standard (61) with RoundAbout™ cable guide |
| | E | base: Standard (62) with RoundAbout™ cable guide |

[Firstmark Controls](#)
 An ISO9001:2000/AS9100B-Compliant Company
 1176 Telecom Drive • Creedmoor, NC 27522 USA
 1-866-912-6232 • Fax: 919-682-3786 •
info@Firstmarkcontrols.com

CO#37219, 8/12/08, Rev.A
 Business hours: Mon-Fri, 8:00am to 5:00pm (Eastern time)
 All specifications subject to change without notice.
 © 1996-2007 Firstmark Controls All rights reserved.

Data Sheet - Series 6 Miniature Position Transducers
With FlexSignal™ Integrated Signal Conditioning

| | | |
|-------------|---|--|
| g (cont) | U | base: Universal; (60, 61 & 62) pn 160016-[1, 3 & 5] & 160029 (Assy 160030-[1, 3 & 5]) |
| | H | base: h; (60) pn 160015-G1 (may also be used with 61 & 62 but mounted out) |
| h | 1 | FOR f = 1 to 8 > electrical termination: flying leads (4-conductor white Teflon cable with 22 AWG flying leads, 60-in (1524-mm) min length, 0.163 in (4.14 mm) nominal diameter) FOR f = 9 > electrical termination: flying leads (10-conductor dark gray PVC cable with 24 AWG, 60-in (1524-mm) min length, 0.250 in (6.35 mm) nominal diameter, -20° to +80° C operating temperature range) |
| | 2 | electrical termination: MS3101E-14S-6PF42-based sealed bulkhead electrical connector and mating 300853 electrical connector (MS3106F-14S-6S) |
| | 3 | electrical termination: Lemo EGG.OB.304.CLL bulkhead electrical connector and mating Lemo FGG.OB.304.CLAD52 electrical connector |
| | 4 | electrical termination: DIN 45326 sealed (per IP68) bulkhead electrical connector and mating electrical connector |

Drawing

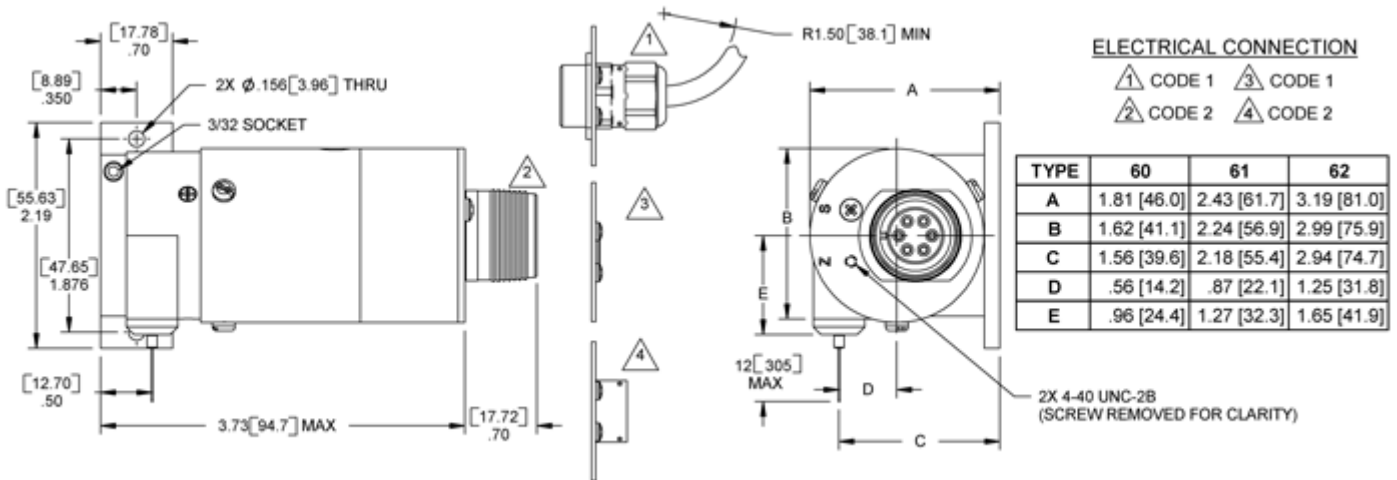

Data Sheet - Series 6 Miniature Position Transducers
With FlexSignal™ Integrated Signal Conditioning

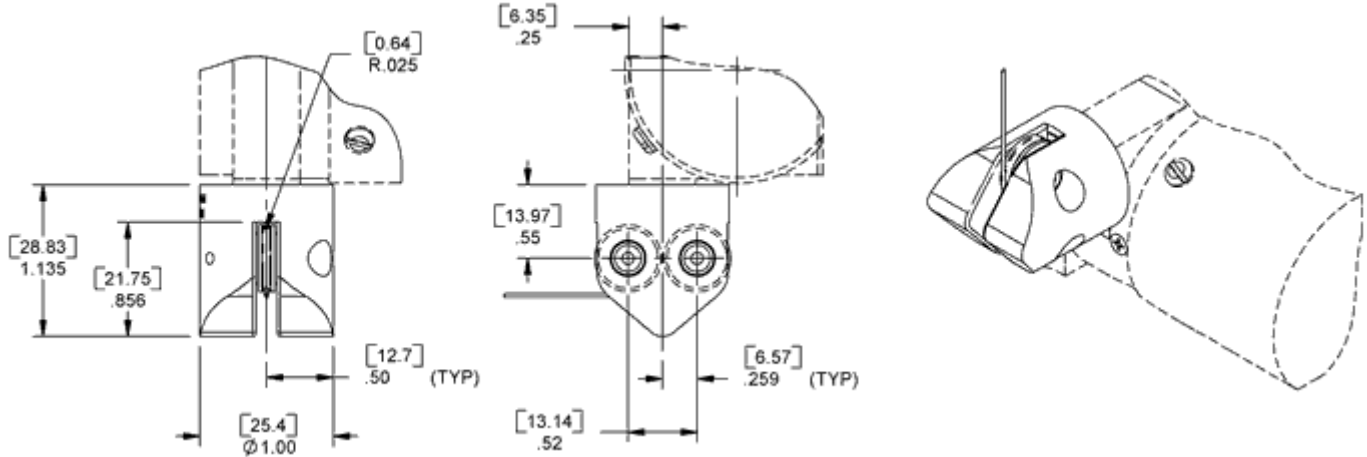

RoundAbout™ cable guide

Related Products

| Part Number | Description |
|---------------------------|------------------|
| 160001-01 | installation kit |

For crimping of hardware to displacement cable, consider the [160001-01 installation kit](#).

Need something not shown? Complete a [Custom Solution Request](#).

All dimensions are REFERENCE and are in inches [mm]

Shaded characteristics are verified during production and test. All others are for REFERENCE and information only.