

Model 7514A Accelerometer



+260°C Charge Output Accelerometer
50pC/g output, 14kHz Bandwidth
Hermetically Sealed
Stud Mount, Side Connector



The **Model 7514A** is a stud mounted piezoelectric charge mode accelerometer with an operating temperature range to +260°C. The accelerometer is designed for high frequency vibration and shock measurements and offers a wide bandwidth to >14kHz with a nominal charge output of 50pC/g. The model 7514A features a hermetically sealed stainless steel housing and a #10-32 stud mount configuration.

FEATURES

- 13pC/g to 50pC/g Sensitivity
- Wide bandwidth up to >14kHz
- Stud Mounted
- Hermetically Sealed
- Annular Shear Mode
- -73°C to +260°C Operating Range
- Stable Temperature Response

APPLICATIONS

- Vibration & Shock Monitoring
- High Temp Applications
- Laboratory Testing
- High Frequency Applications
- Gearbox Vibration Monitoring

dimensions

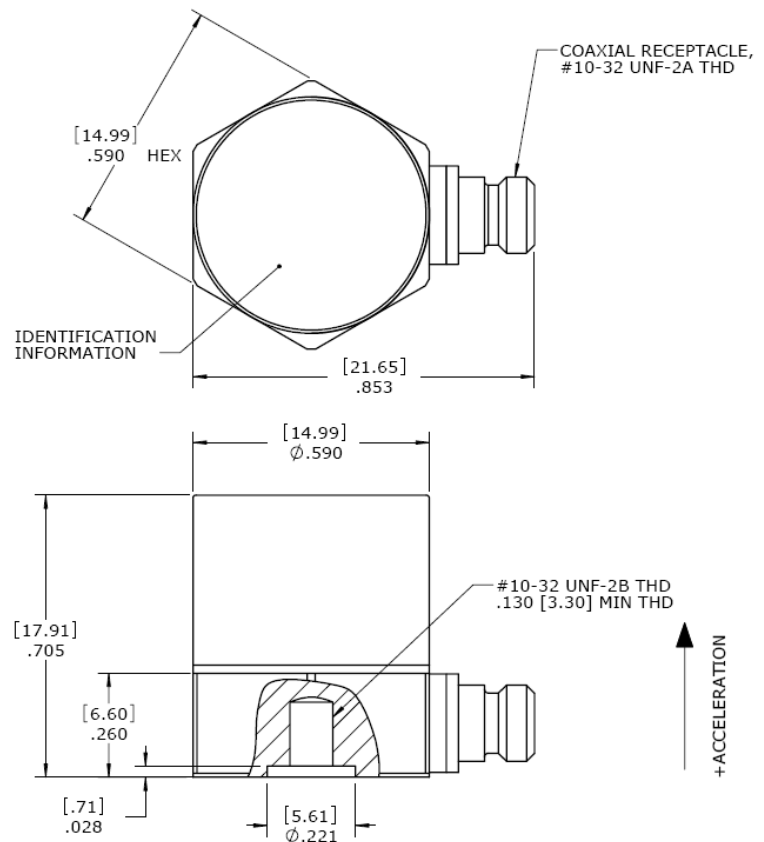

ACCELEROMETER

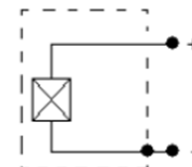

Model 7514A Accelerometer

performance specifications

All values are typical at +24°C, 80Hz unless otherwise stated. Measurement Specialties reserves the right to update and change these specifications without notice. Standard product parameters are described in PSC-1003 for Plug & Play AC Accelerometers.

Parameters

DYNAMIC

	-50	-30	-20	-13	Notes
Dash Number	50	30	20	13	Typical
Sensitivity (pC/g)	40	24	14.5	9.0	Minimum
Frequency Response (Hz) ²	0.5-6000	0.5-7000	0.5-9000	0.5-11000	±10%
Frequency Response (Hz) ²	0.1-9000	0.1-10000	0.1-12000	0.1-14000	±2dB
Natural Frequency (Hz)	26000	28000	30000	33000	
Non-Linearity (%FSO)	±1/1000g	±1/1000g	±1/1000g	±1/1000g	
Transverse Sensitivity (%)	<5	<5	<5	<5	
Dynamic Range (g) ¹	±500	±800	±1250	±2000	
Shock Limit (g)	10000	10000	10000	10000	
Weight (grams)	25	22	20	19	

ELECTRICAL

Capacitance (pF)	1050				Nominal
Insulation Resistance (MΩ)	>100				@ 100Vdc
Grounding	Case Grounded				

ENVIRONMENTAL

Temperature Response (%)	See Typical Temperature Response Curve
Operating Temperature (°C)	-73 to +260
Storage Temperature (°C)	-73 to +260
Humidity	Hermetically Sealed, IP67

PHYSICAL

Sensing Element	Ceramic (shear mode)
Case Material	Stainless Steel
Electrical Connector	10-32 Coaxial Receptacle
Mounting	#10-32 to #10-32 Mounting Stud (included)
Mounting Torque	18 lb-in (2.0 N-m)

¹ Operating range over which the accelerometer meets the linearity specifications

² Low-end response of the accelerometer is a function of its associated electronics.

Calibration supplied:	CS-FREQ-0100	NIST Traceable Amplitude Calibration from 20Hz to ±2dB Frequency Response Limit
Supplied accessories:	AC-D02298	10-32 to 10-32 mounting stud
Optional accessories:	320-XXX	Cable Assembly, 10-32 to 10-32 (XXX designates length in inches, 10ft standard)
	324-XXX	Cable Assembly, 10-32 to BNC (XXX designates length in inches, 10ft standard)
	130	In-Line Charge Converter
	161A	4-Channel PE & IEPE Signal Conditioner
	AC-A03470	Adhesive Mounting Adaptor
	AC-A03471	Magnetic Mounting Adaptor

The information in this sheet has been carefully reviewed and is believed to be accurate; however, no responsibility is assumed for inaccuracies. Furthermore, this information does not convey to the purchaser of such devices any license under the patent rights to the manufacturer. Measurement Specialties, Inc. reserves the right to make changes without further notice to any product herein. Measurement Specialties, Inc. makes no warranty, representation or guarantee regarding the suitability of its product for any particular purpose, nor does Measurement Specialties, Inc. assume any liability arising out of the application or use of any product or circuit and specifically disclaims any and all liability, including without limitation consequential or incidental damages. Typical parameters can and do vary in different applications. All operating parameters must be validated for each customer application by customer's technical experts. Measurement Specialties, Inc. does not convey any license under its patent rights nor the rights of others.

Model 7514A Accelerometer

performance specifications

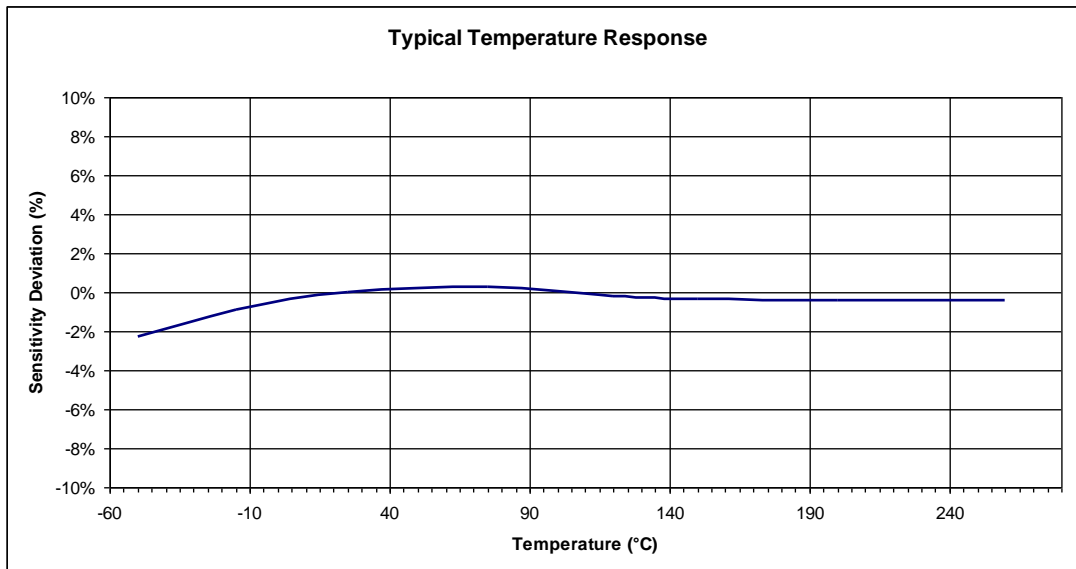
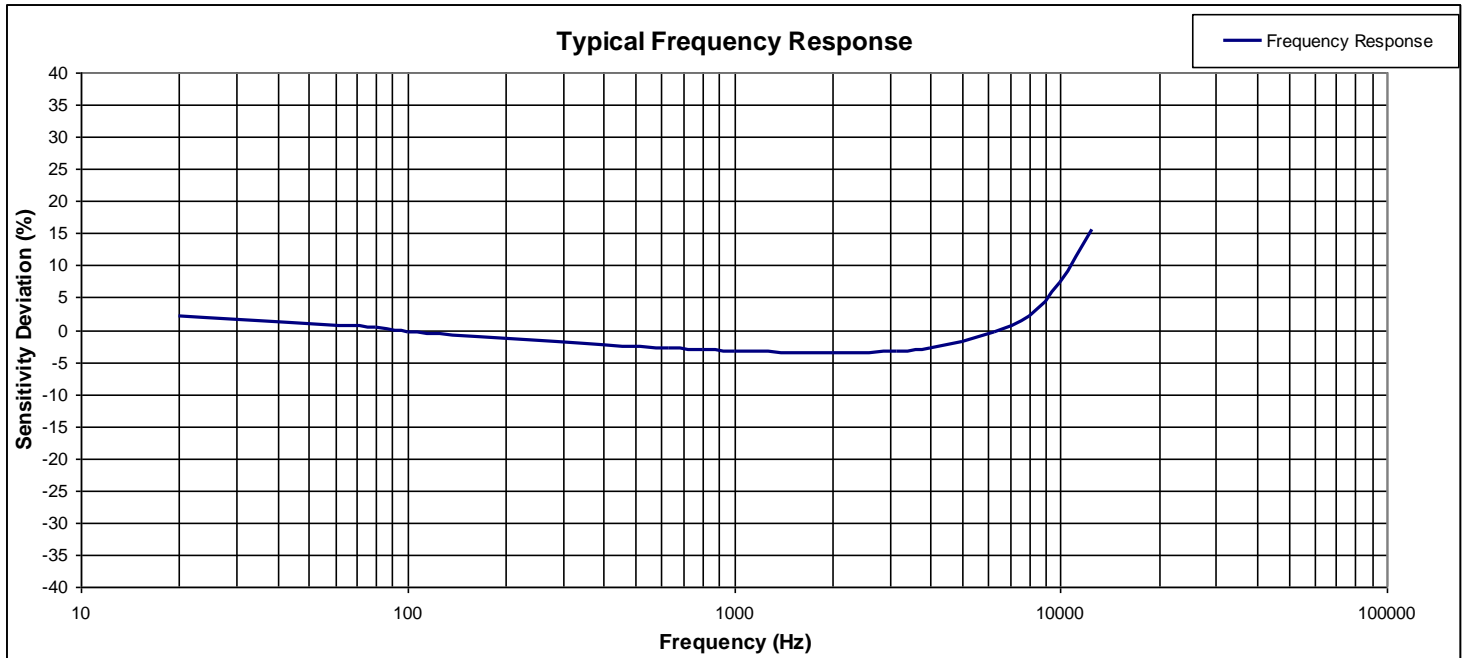

ordering info

PART NUMBERING Model Number+Sensitivity

7514A-GG
I_____ (50 is 50pC/g)

Example: 7514A-50
Model 7514A, 50pC/g