

New **SPEEDBOX-INS Compact Dual Antenna**

Fully integrated IMU and GPS system for automotive testing.

New for 2019 - Compact Dual Antenna for stationary initialisation

Stationary alignment of the system

Fitted and test ready in a few minutes:

1. Install 2. Converge 3. Test

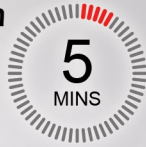

Simplified installation compared to any competitive dual antenna system:

No initialisation, no figure of eights, no special convergence procedure.

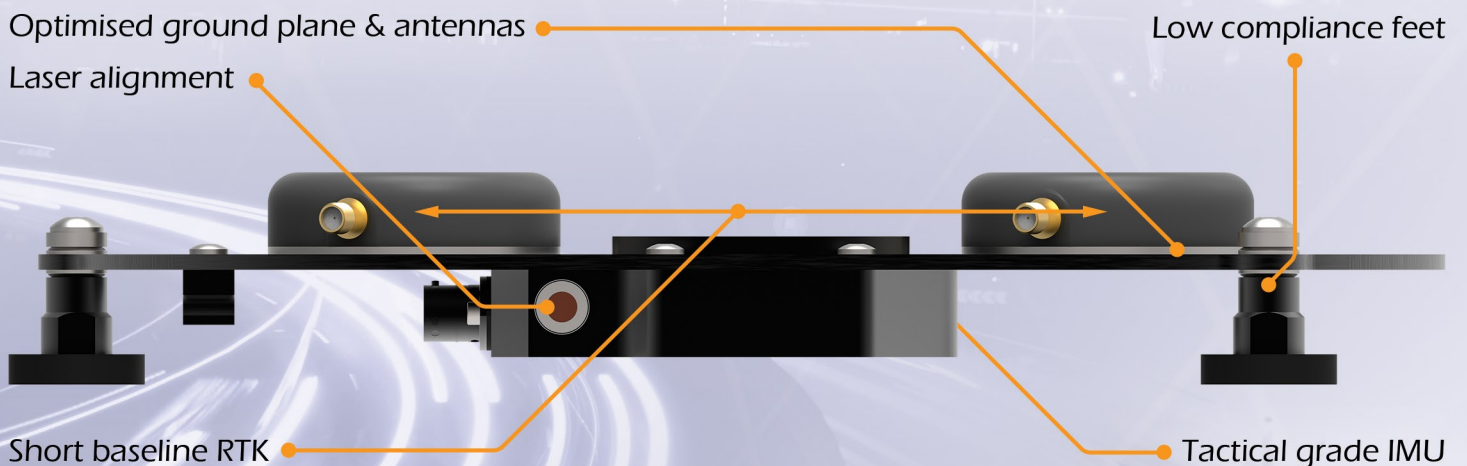

- Position, Distances, Velocity
- Roll, Pitch, Yaw
- Heading, Gradient
- Slip angle
- All at 200Hz, no interpolation, low latency
- Brake testing
- Chassis development
- ADAS verification ***New for 2019***

The SPEEDBOX-INS range is our purpose designed automotive testing solution offering enhanced accuracy and flexibility over the standard SPEEDBOX product. The system comprises of a SPEEDBOX unit coupled with an IMU sensor and antenna assembly mounted to the roof of the vehicle. The SPEEDBOX-INS system is used extensively by a number of international automotive OEMs for testing and development. The system's compact size, accuracy, and flexibility makes it ideal for a wide range of vehicle types and test applications.

- Dual antenna enables stationary initialisation of INS system, ideal for testing from a "cold" vehicle
- <10cm error for 100 to 0 km/h braking tests
- 2cm absolute positional accuracy with optional GPS2 RTK unit
- Compact and quick to install
- 200Hz output on serial and CAN
- 0.08 degrees yaw, 0.04 degrees roll and pitch accuracy
- Tactical grade IMU ensures no outages even with challenging GPS conditions

New **SPEEDBOX-INS Compact Dual Antenna**

The rooftop IMU sensor includes 3 high performance gyro and accelerometer sensors. The SPEEDBOX unit combines the raw inertial and GPS outputs using adaptive Kalman filtering. All measurements have a very low latency of just a few milliseconds, and are output at a rate of 200Hz with no interpolation. The IMU data can fill any short GPS outages without any significant loss in accuracy, making it ideal for on highway testing as well as test tracks.

Updates for 2019 include:

- Updated Kalman filter algorithms to further optimise performance
- ADAS functionality
- Lower profile sensor assembly for lower aerodynamic drag
- Improved installation accuracy with laser alignment
- Optional mounting feet for installation on aluminium or composite roofs
- Lower compliance mounting to reduce vibration noise
- Optimised RF signal quality for reception in challenging environments

Simplified mounting

The new 2019 mounting now includes laser alignment. As with all INS systems it is essential that the IMU is mounted in a vehicle squarely, to prevent vehicle roll being interpreted as pitch, and pitch as roll. In fact in most cases the mounting accuracy is what limits the overall roll and pitch measurement accuracy. To squarely mount the SPEEDBOX-INS antenna assembly, lasers align with equal measured points on each side of the vehicle.

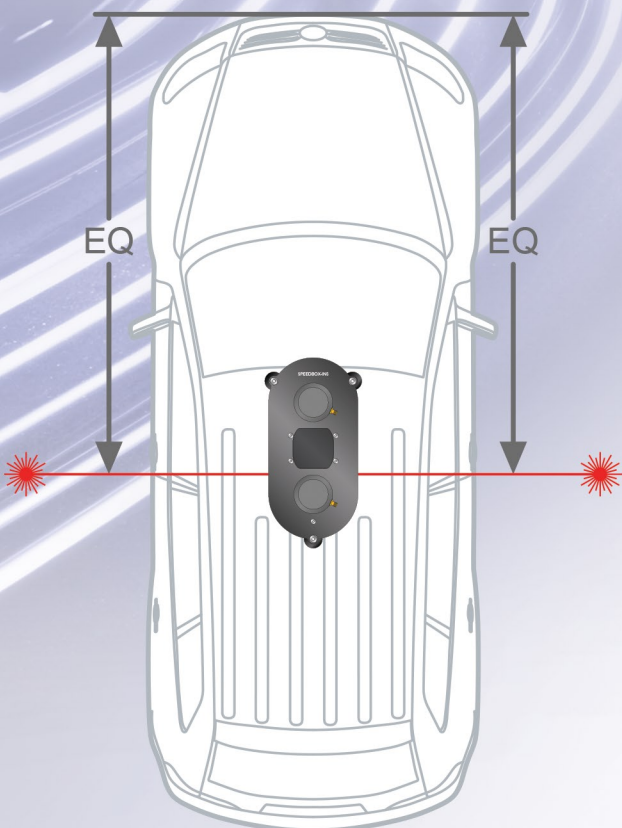

Not to scale

The example below shows the SPEEDBOX INS system compared against a GPS only system in difficult GPS conditions. With trees lining the road and the vehicle driving under the road bridge. The SPEEDBOX INS system retains excellent data throughout

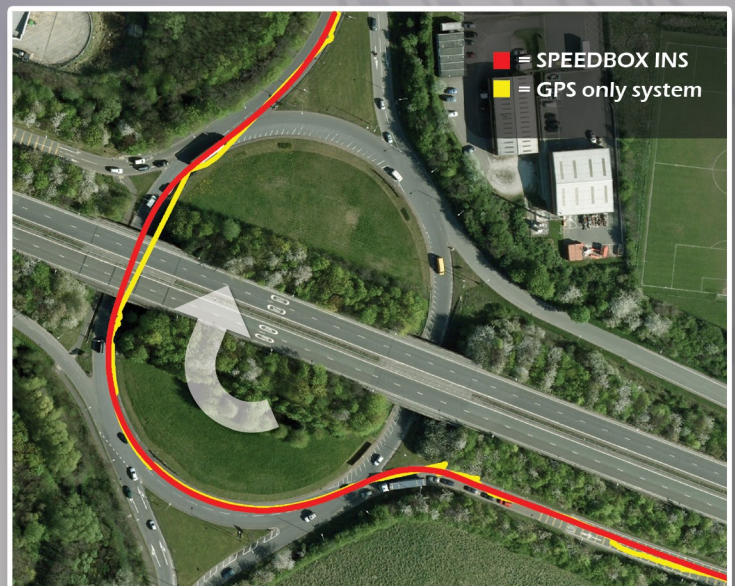

New SPEEDBOX-INS Compact Dual Antenna

No Speed Overshoot Under Braking:

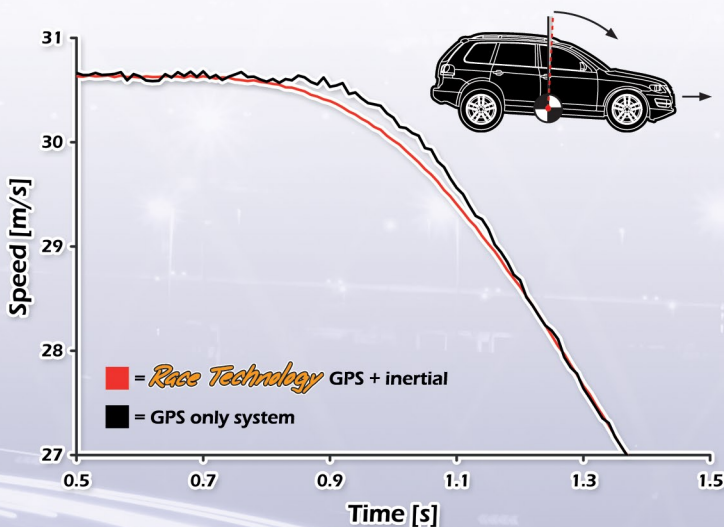

No Speed Overshoot

During brake testing a GPS-only system suffers from speed overshoot, as the brakes are applied the vehicle pitches and the roof mounted GPS antenna accelerates forwards. The time difference as the car decelerates past 100km/h (27.78m/s) and triggers the start of the test is only a few milliseconds (15-20ms), but at 100km/h the distance travelled in a few milliseconds is significant (~0.5m).

The SPEEDBOX-INS allows the measurement point to be accurately offset to the centre of gravity giving a true speed measurement with no overshoot. The inertial sensors accurately measure pitch and rotation rates to the reference point achieving unbeatable accuracy of just a few cm for all automotive braking tests.

Consistent High Accuracy Results

The SPEEDBOX-INS gives consistent high accuracy measurements under all testing scenarios. Measurements are precise and unaffected by accelerations and decelerations; vehicle pitch, roll and yaw.

Higher Accuracy:

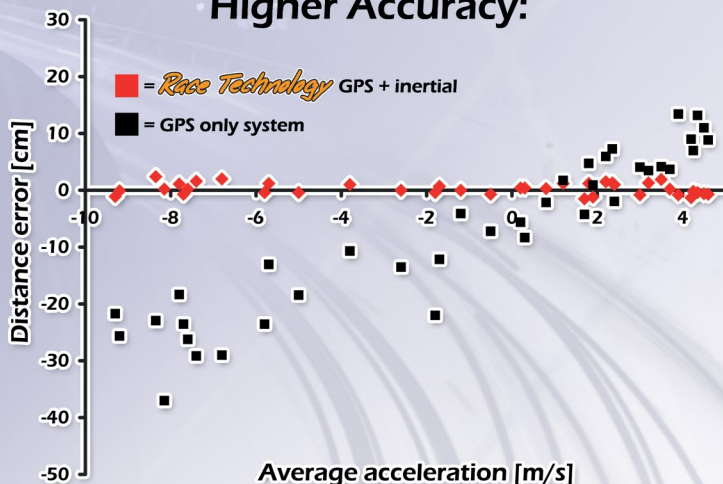

Lower Noise:

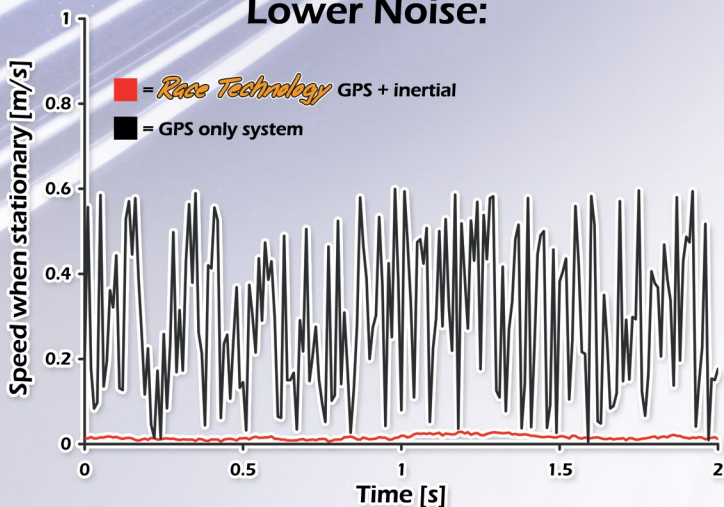

Low Speed Noise

Low speed tests provide the toughest challenge to the accuracy of non-contact speed measurement systems. Errors often show up as high noise when stationary. Many manufacturers remove this noise by implementing a crude zero-clamp on the output, so it is impossible to see any data below 0.5m/s, for example. This is a particular problem with all GPS only speed sensing systems as speed errors at rest are normally significantly higher than speed errors when moving.

New **SPEEDBOX-INS Compact Dual Antenna**

	Dual Antenna
Accelerations	200Hz, 0.01m/s ²
Speed	200Hz, 0.015m/s
Distance	200Hz, 3cm in 40m
Position	200Hz, 2m (2cm with GPS RTK option)
Roll / Pitch / Yaw rate	200Hz, 0.01 deg/s
Yaw accuracy	200Hz, 0.08 deg
Roll / Pitch accuracy	200Hz, 0.04 deg
Initialisation	While stationary or moving
Braking test accuracy	<10cm (100 to 0 km/h)
	Dual Antenna

Race Technology Ltd (UK)

16 King Street, Eastwood, Nottingham, NG16 3DA

Tel: +44 (0)1773 537620

Fax: +44 (0)1773 537621

Email: sales@race-technology.com

