

Capacitive Accelerometer

BST 58K1

uniaxial

Features

- Anodized Aluminium Housing
- Option: Housing with connector
- DC Response
- Voltage Output
- Calibration

Applications

- Motion
- Automotive
- Truck and Busses
- Train
- Comfort

Description

The new model BST 58K1 is a uniaxial accelerometer based on variable capacitive technology with a good frequency response. The accelerometers are designed for relatively low amplitudes. Do to the mounting with two screws. The sensor has 6m very high rugged and flexible cable this makes it easy to connect the sensor on data acquisition systems. It operates between 8 and 30 VDC unregulated. The sensor is available with a connector in the housing as well. This sensor has more possibilities for mounting.

As an option, we supply the sensor with connector, Dallas ID or TEDS module. A calibration for the sensor is obligatory.

Specifications

Range	from 2 g to 200 g
Supply voltage	8 to 30 VDC unregulated
Power Consumption	max. 10 mA
Zero measurement output	+/- 80 mV typ in Differential Mode (≥ 10 g) +/- 150 mV typ in Differential Mode (2 and 5 g) 2500 mV DC +/- 150 mV in Single Ended Mode
Sensitivity	10 mV/g up to 2000 mV/g
Frequency 5% typ	0 Hz to 1000 Hz
Shock limit	5000 g
Operation Temperature	-20° to 100° C
Weight	12 grams
Dimensions	16,0 x 16,0 x 16.0 mm (l x w x h)
Case material	anodized Aluminium
Screws	2 pcs M3x25

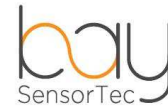

Individual Data

Range g	2	5	10	25	50	100	200
Frequency	0-90	0-90	0-250	0-400	0-650	0-700	0-850
Sensitivity mV/g	2000	800	400	160	80	40	20
Noise $\mu\text{g}/\sqrt{\text{Hz}}$	7	12	18	25	50	100	200

Dimensions

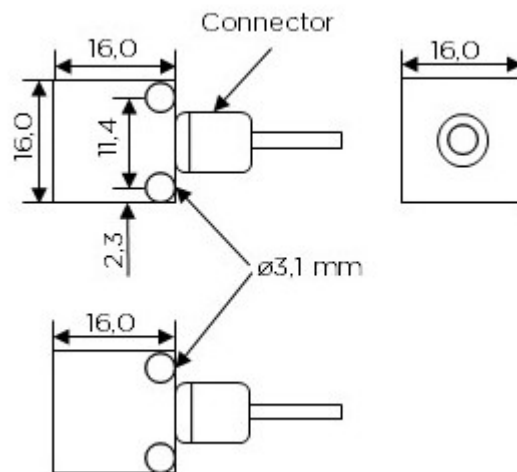

Cable Code Differential

Red = Excitation + Green = Signal +
Black = Excitation - White = Signal -

Cable Code Single ended

Red = Excitation + Black = Excitation - Green = Signal

Order Information

BST 58K1-050-6Z
58K1 = Model Name
050 = Range 50g
6 = 6m shielded cable
Z = no connector